

351095112

Building Layout

2/16/24

NOT FOR CONSTRUCTION

○ Dia= 5/8"

⊗ Dia= 3/4"

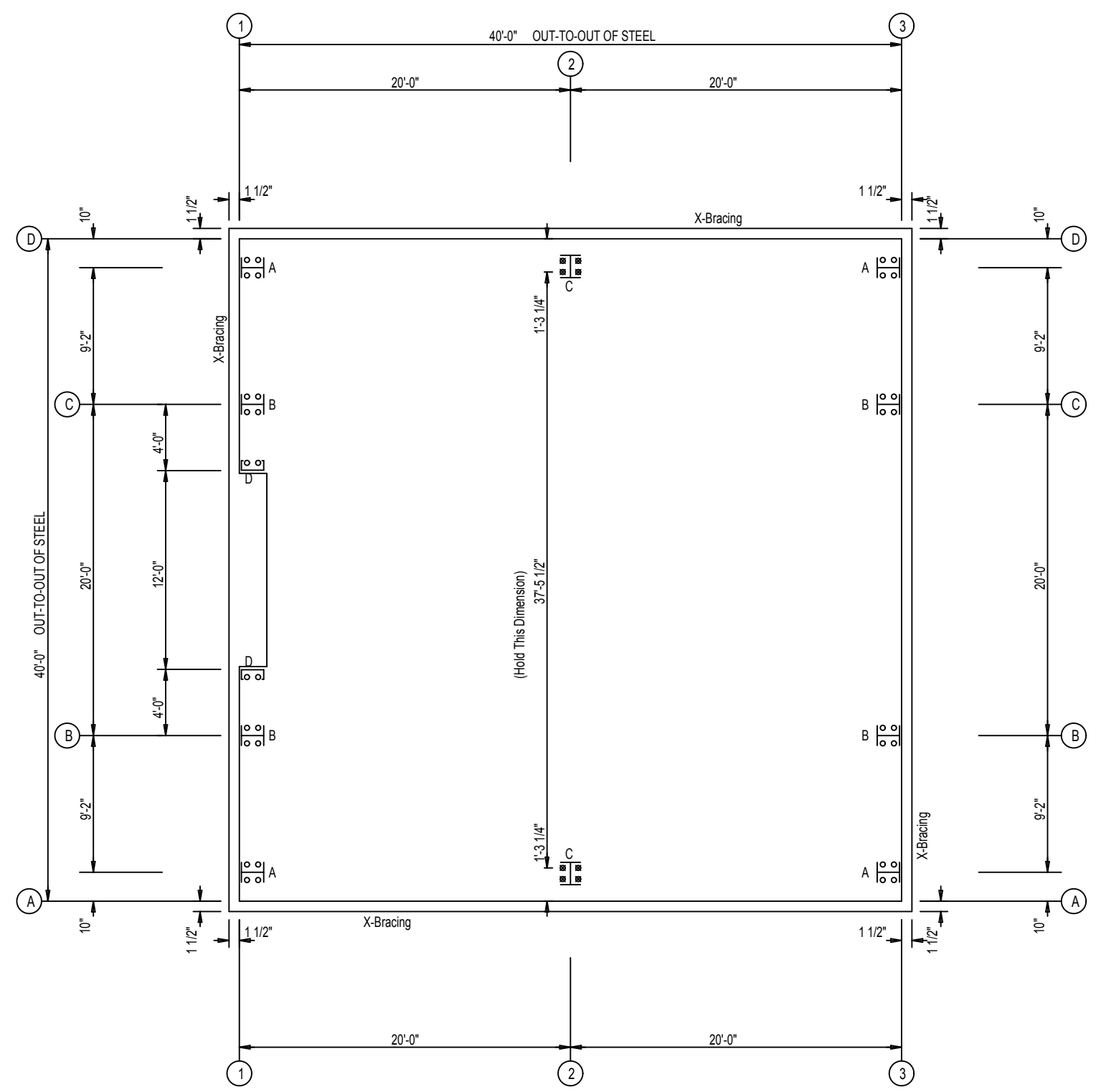

ANCHOR BOLT PLAN

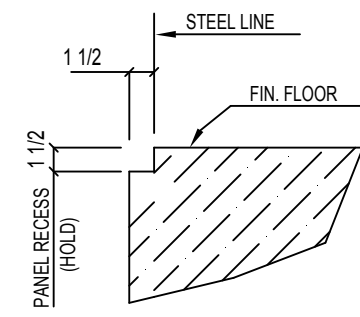

CONCRETE NOTCH DETAIL

NOT FOR CONSTRUCTION

SPECIAL BOLTS					
ROOF PLAN					
○ ID	QUAN	TYPE	DIA	LENGTH	WASH
1	2	A325	1/2"	1 1/4"	2

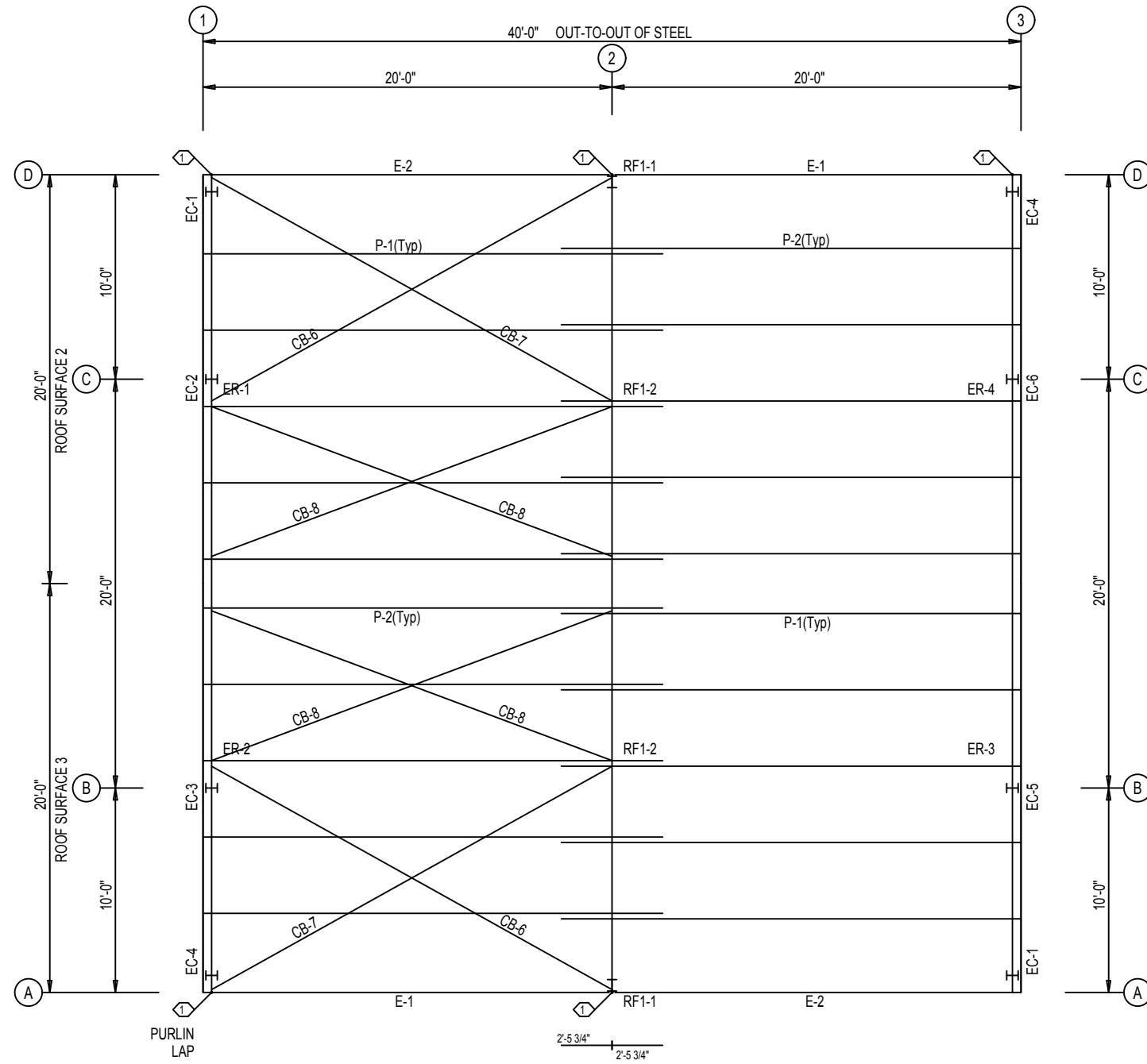

ROOF FRAMING PLAN

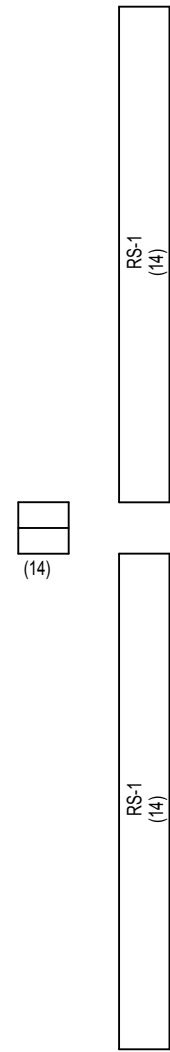

ROOF SHEETING

PANELS: 26 Gauge PBR
Burnished Slate

NOT FOR CONSTRUCTION

SPECIAL BOLTS					
ROOF PLAN					
○ ID	QUAN	TYPE	DIA	LENGTH	WASH
1	2	A325	1/2"	1 1/4"	2

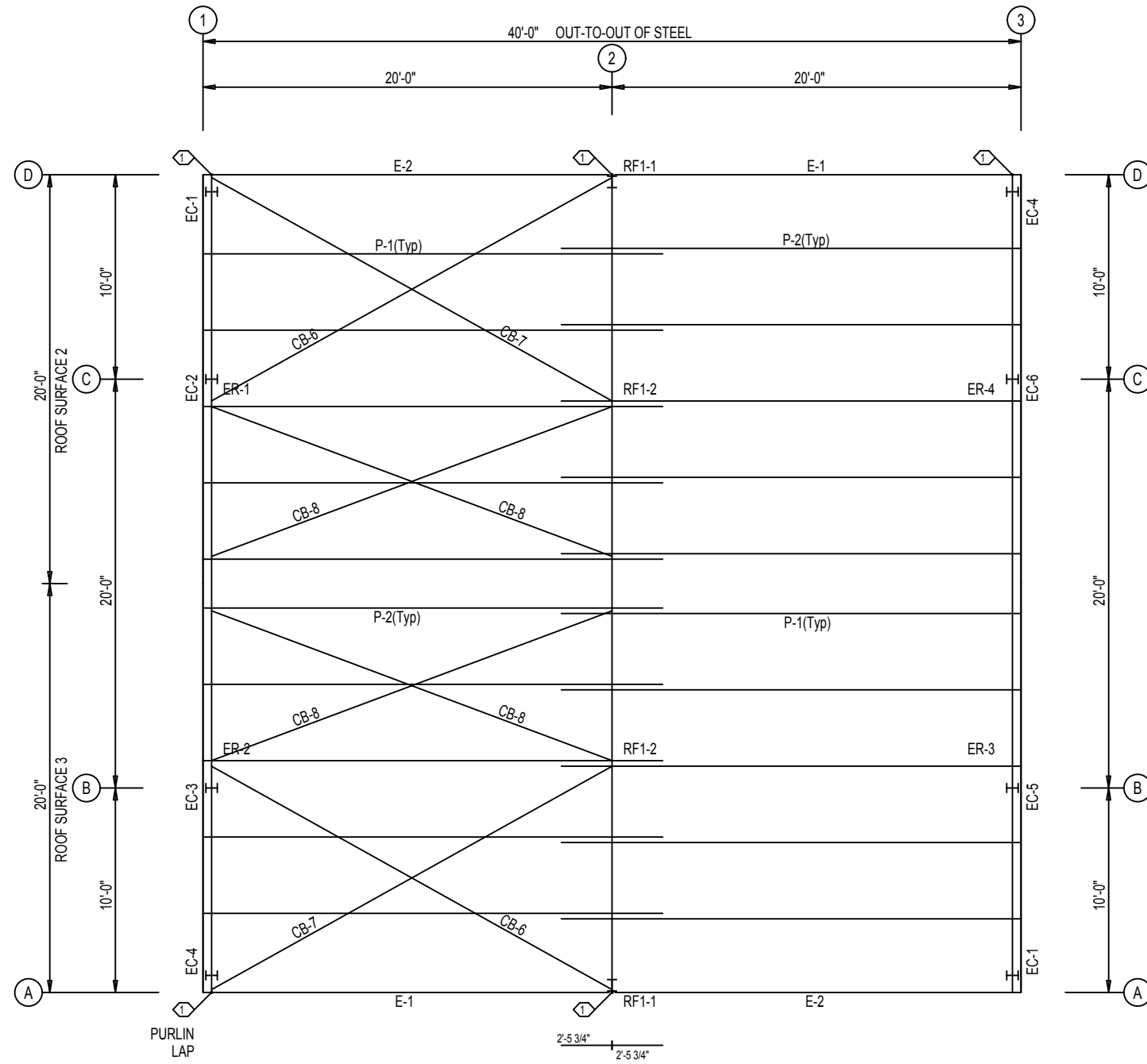

ROOF FRAMING PLAN

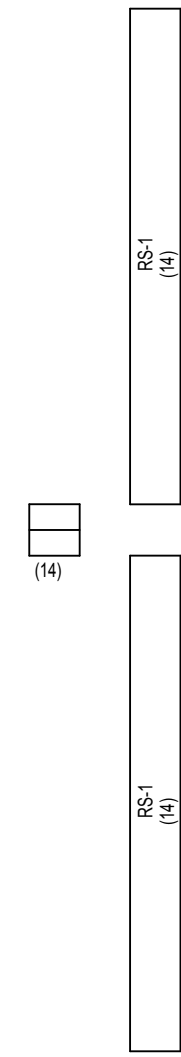

ROOF SHEETING
 PANELS: 26 Gauge PBR
 Burnished Slate

NOT FOR CONSTRUCTION

SPECIAL BOLTS					
ID	QUAN	TYPE	DIA	LENGTH	WASH
1	2	A325	1/2"	1 1/4"	2

CONNECTION PLATES	
FRAME LINE A	
ID	MARK/PART
1	PC78

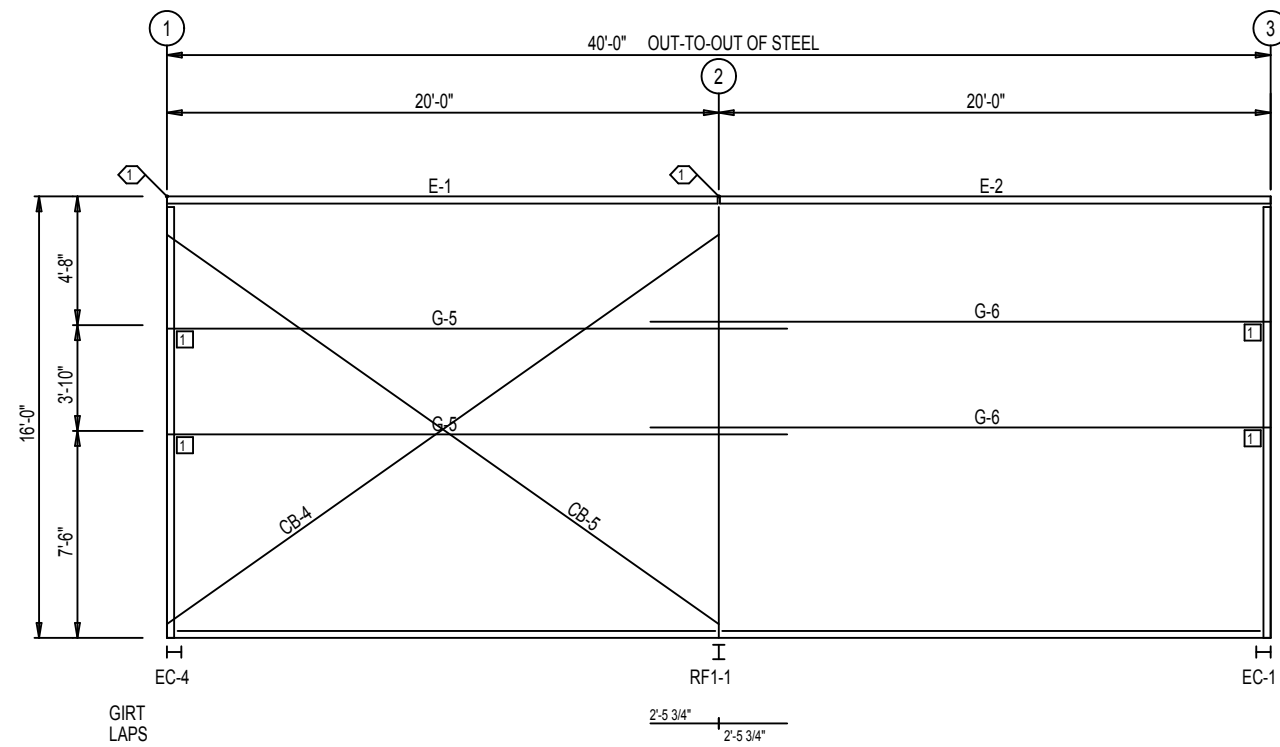

SIDEWALL FRAMING: FRAME LINE A

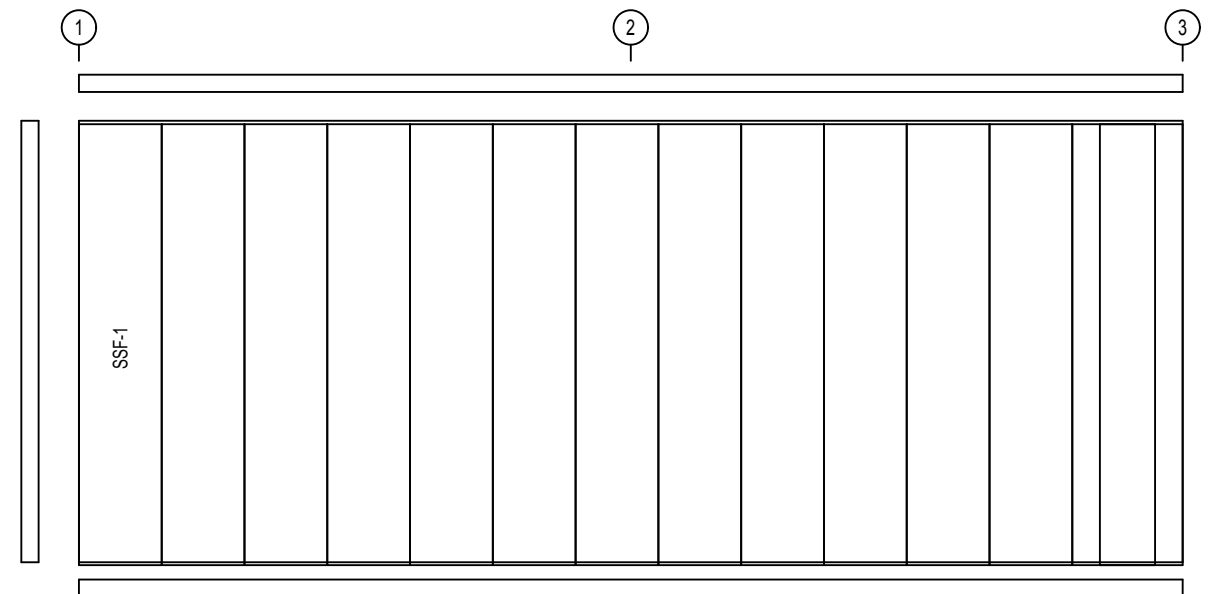

SIDEWALL SHEETING & TRIM: FRAME LINE A

PANELS: 26 Gauge PBR - Burnished Slate

NOT FOR CONSTRUCTION

SPECIAL BOLTS					
ID	QUAN	TYPE	DIA	LENGTH	WASH
1	2	A325	1/2"	1 1/4"	2

CONNECTION PLATES	
FRAME LINE D	
ID	MARK/PART
1	PC78

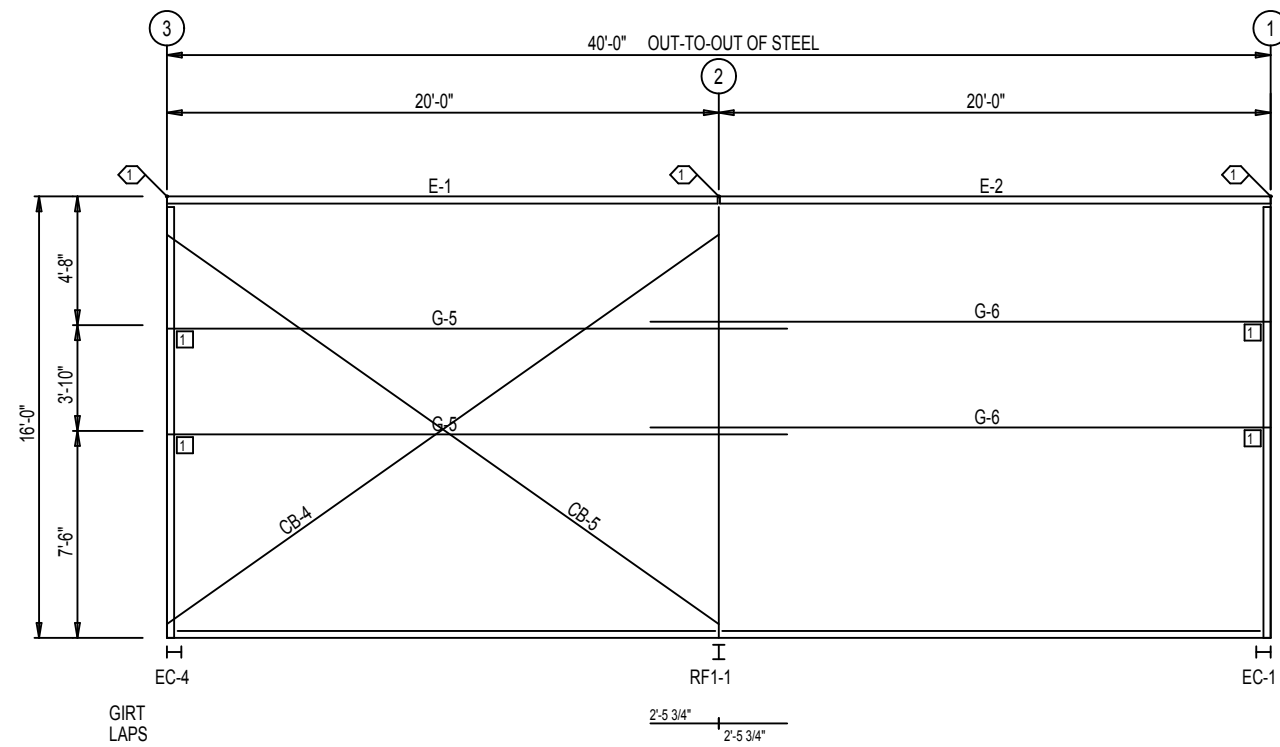

SIDEWALL FRAMING: FRAME LINE D

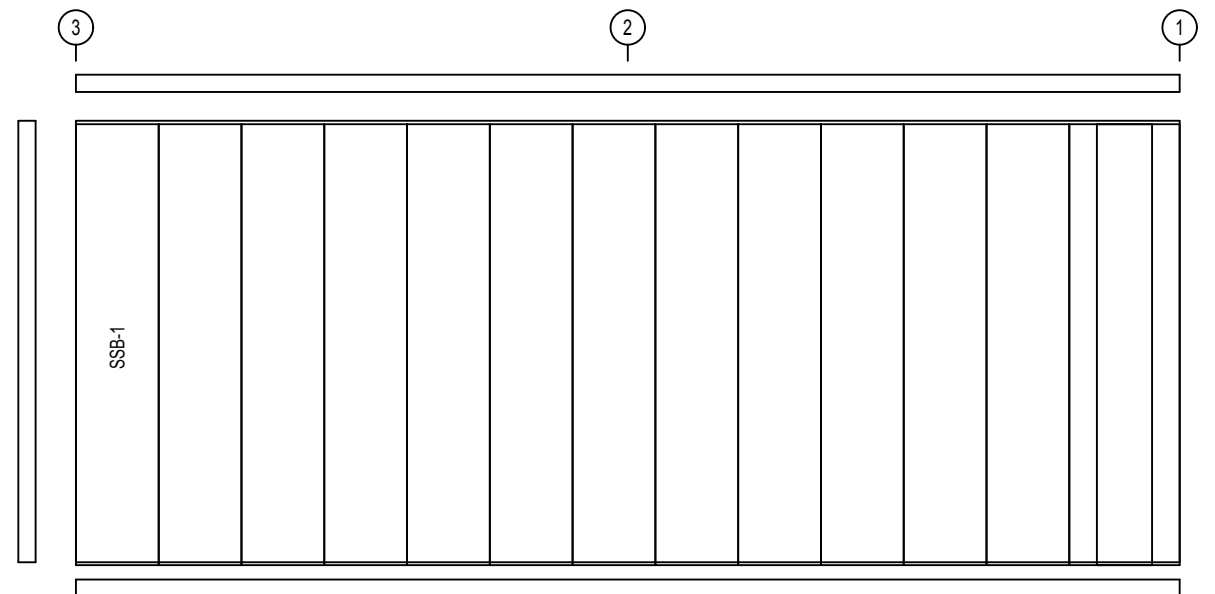

SIDEWALL SHEETING & TRIM: FRAME LINE D

PANELS: 26 Gauge PBR - Burnished Slate

NOT FOR CONSTRUCTION

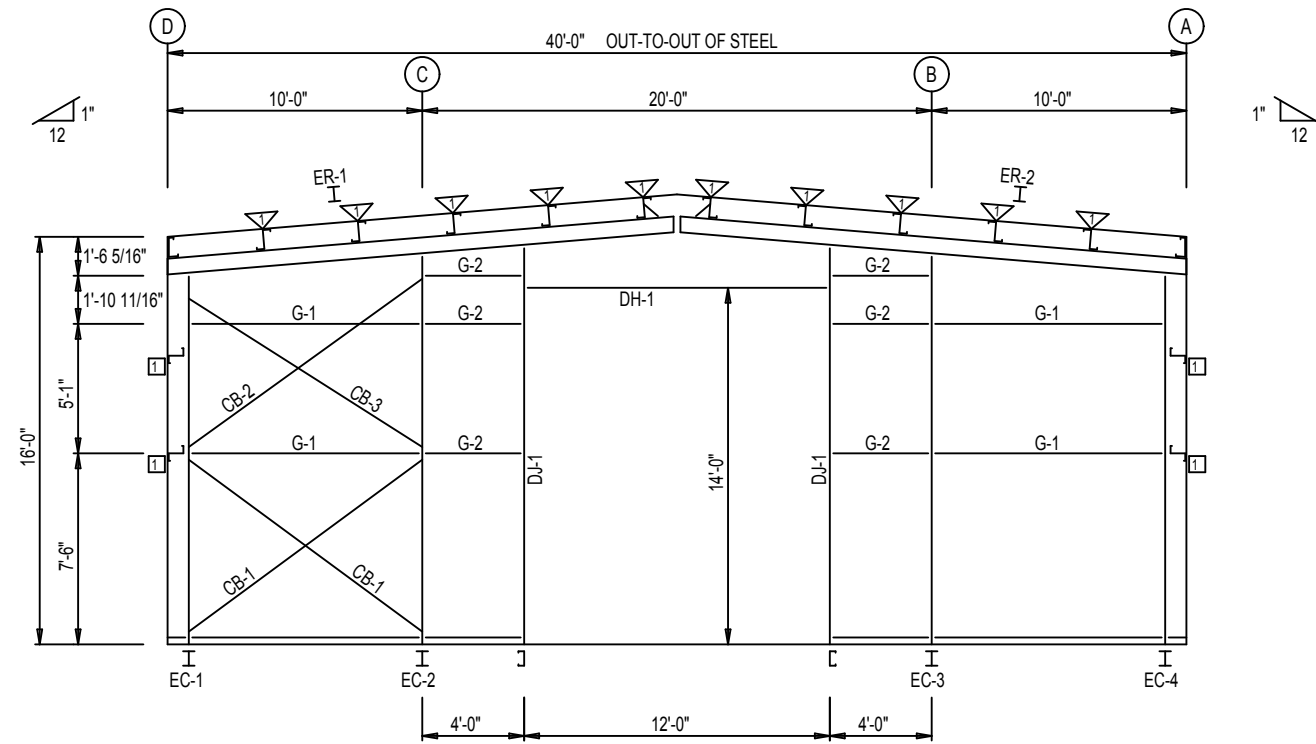

ENDWALL FRAMING: FRAME LINE 1

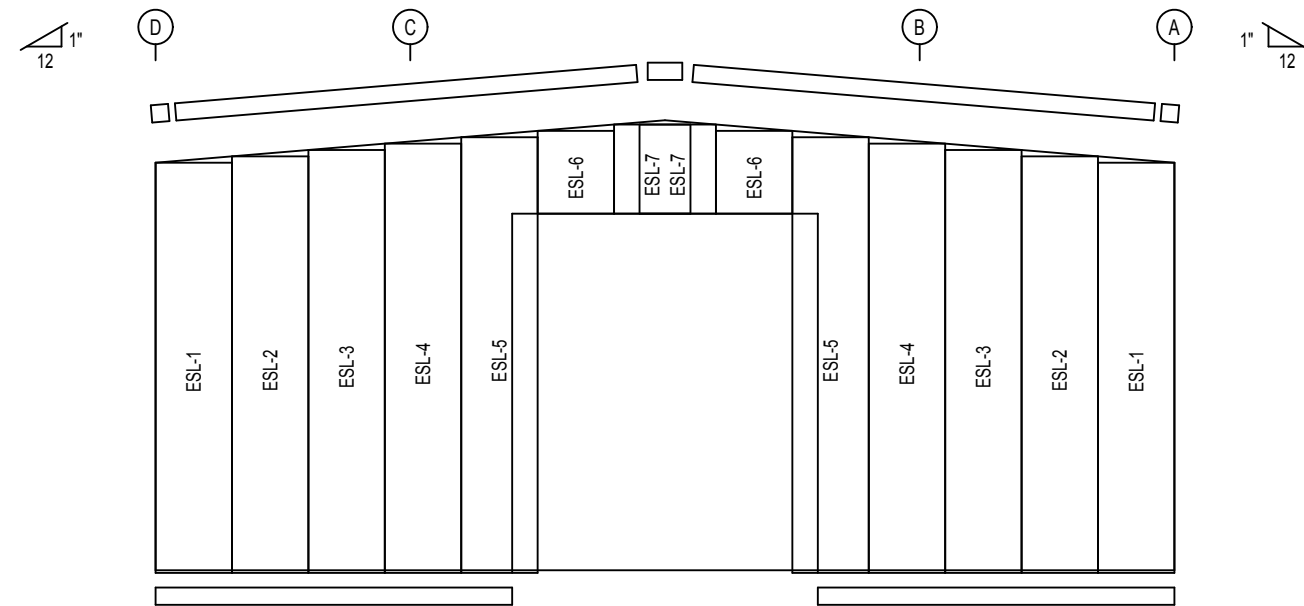

ENDWALL SHEETING & TRIM: FRAME LINE 1

PANELS: 26 Gauge PBR - Burnished Slate

BOLT TABLE				
FRAME LINE 1				
LOCATION	QUAN	TYPE	DIA	LENGTH
ER-1/ER-2	8	A325	5/8"	2"
Columns/Raf	4	A325	1/2"	1 1/4"
Jamb	2	A325	1/2"	1 1/4"

FLANGE BRACE TABLE		
FRAME LINE 1		
▽ ID	PART	LENGTH
FB30.3	L2X2X14G	2'-6 1/4"

CONNECTION PLATES	
FRAME LINE 1	
□ ID	MARK/PART
1	PC78

NOT FOR CONSTRUCTION

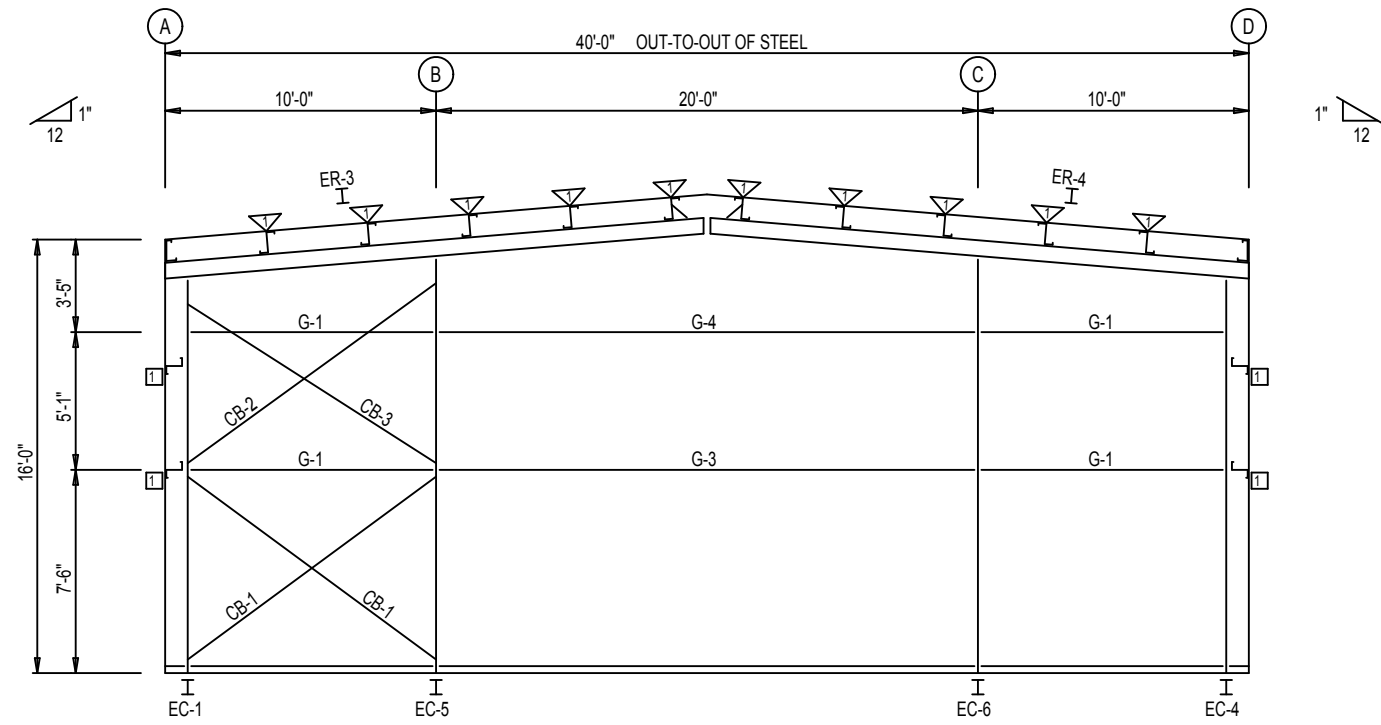

ENDWALL FRAMING: FRAME LINE 3

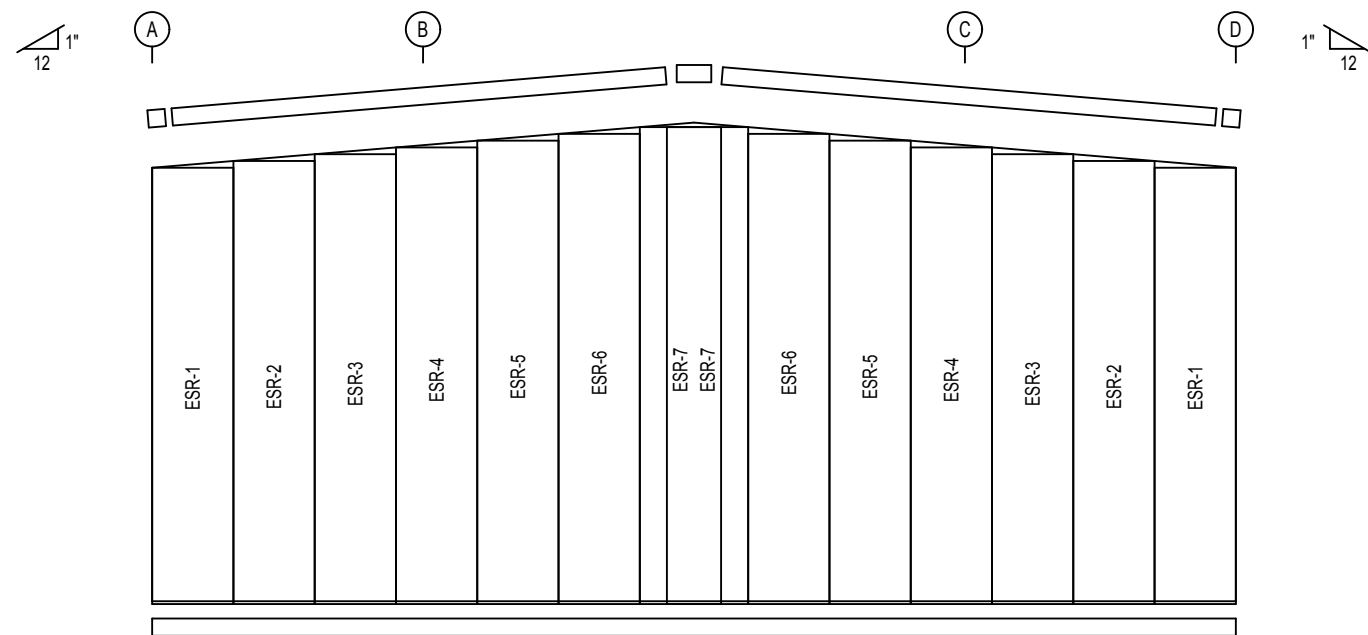

ENDWALL SHEETING & TRIM: FRAME LINE 3

PANELS: 26 Gauge PBR - Burnished Slate

BOLT TABLE				
FRAME LINE 3				
LOCATION	QUAN	TYPE	DIA	LENGTH
ER-3/ER-4	8	A325	5/8"	2"
Columns/Raf	4	A325	1/2"	1 1/4"

FLANGE BRACE TABLE		
FRAME LINE 3		
▽ ID	PART	LENGTH
FB30.3	L2X2X14G	2'-6 1/4"

CONNECTION PLATES	
FRAME LINE 3	
□ ID	MARK/PART
1	PC78

NOT FOR CONSTRUCTION

