

**NOT FOR CONSTRUCTION**

○ Dia= 5/8"

⊗ Dia= 3/4"

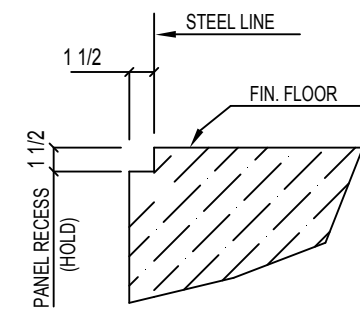
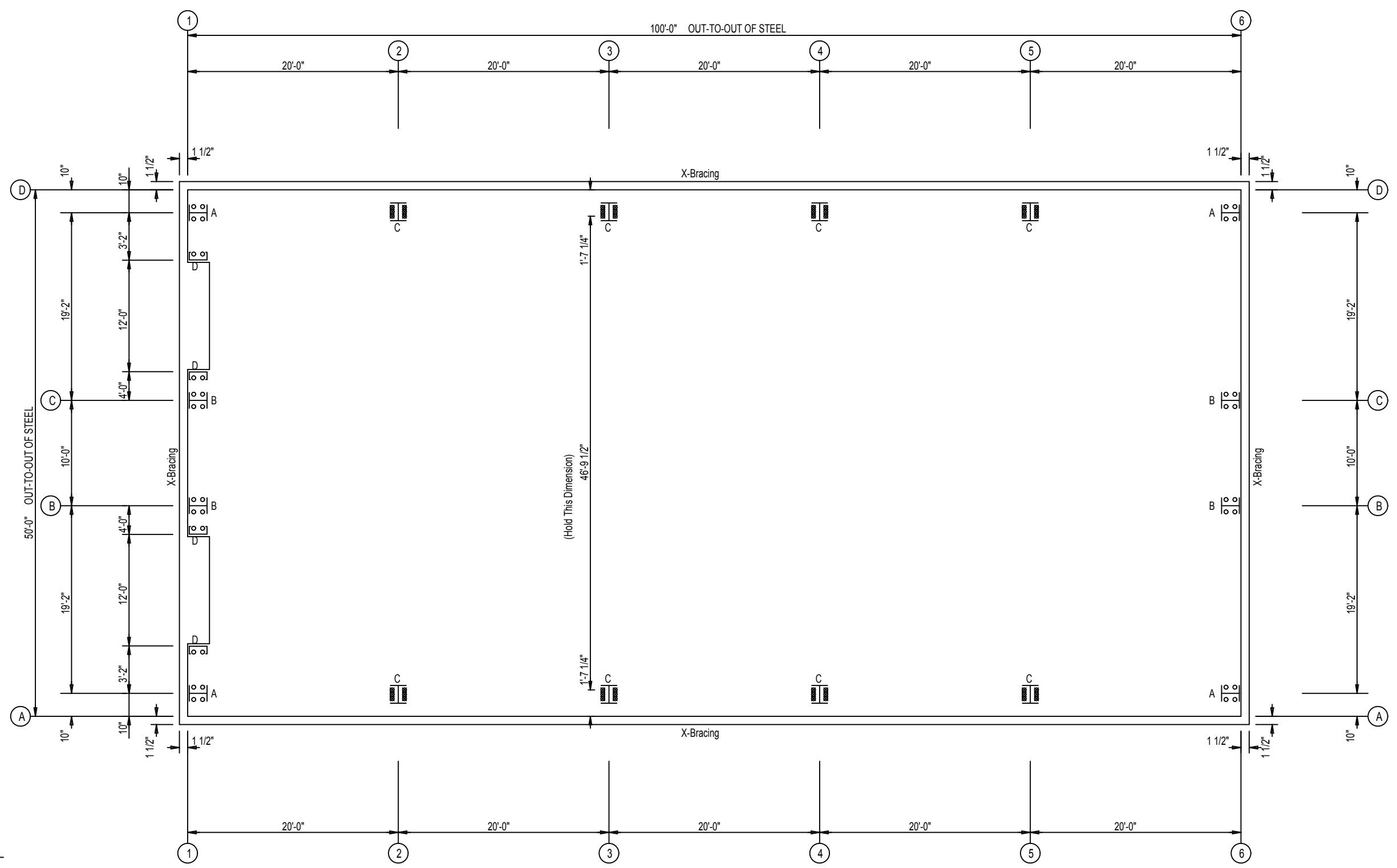

CONCRETE NOTCH DETAIL

**NOT FOR CONSTRUCTION**

SPECIAL BOLTS					
ROOF PLAN					
○ ID	QUAN	TYPE	DIA	LENGTH	WASH
1	2	A325	1/2"	1 1/4"	2
2	4	A325	1/2"	1 1/4"	0

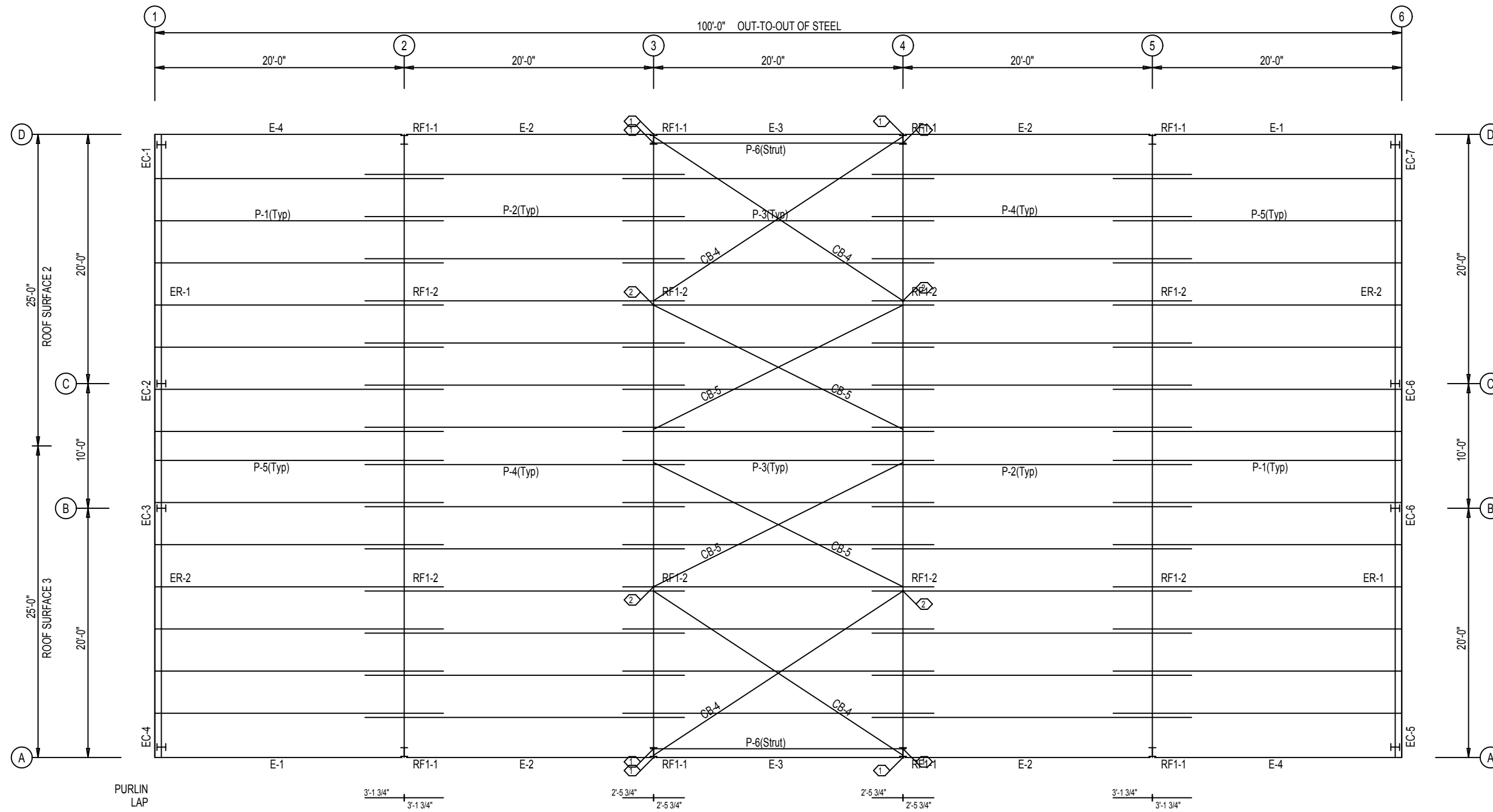

ROOF FRAMING PLAN

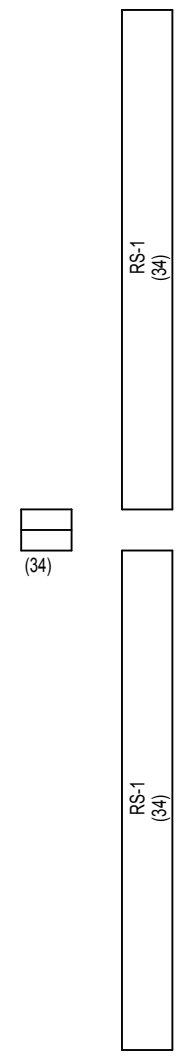

ROOF SHEETING  
PANELS: 26 Gauge PBR  
Burnished Slate

**NOT FOR CONSTRUCTION**

SPECIAL BOLTS					
ROOF PLAN					
○ ID	QUAN	TYPE	DIA	LENGTH	WASH
1	2	A325	1/2"	1 1/4"	2
2	4	A325	1/2"	1 1/4"	0

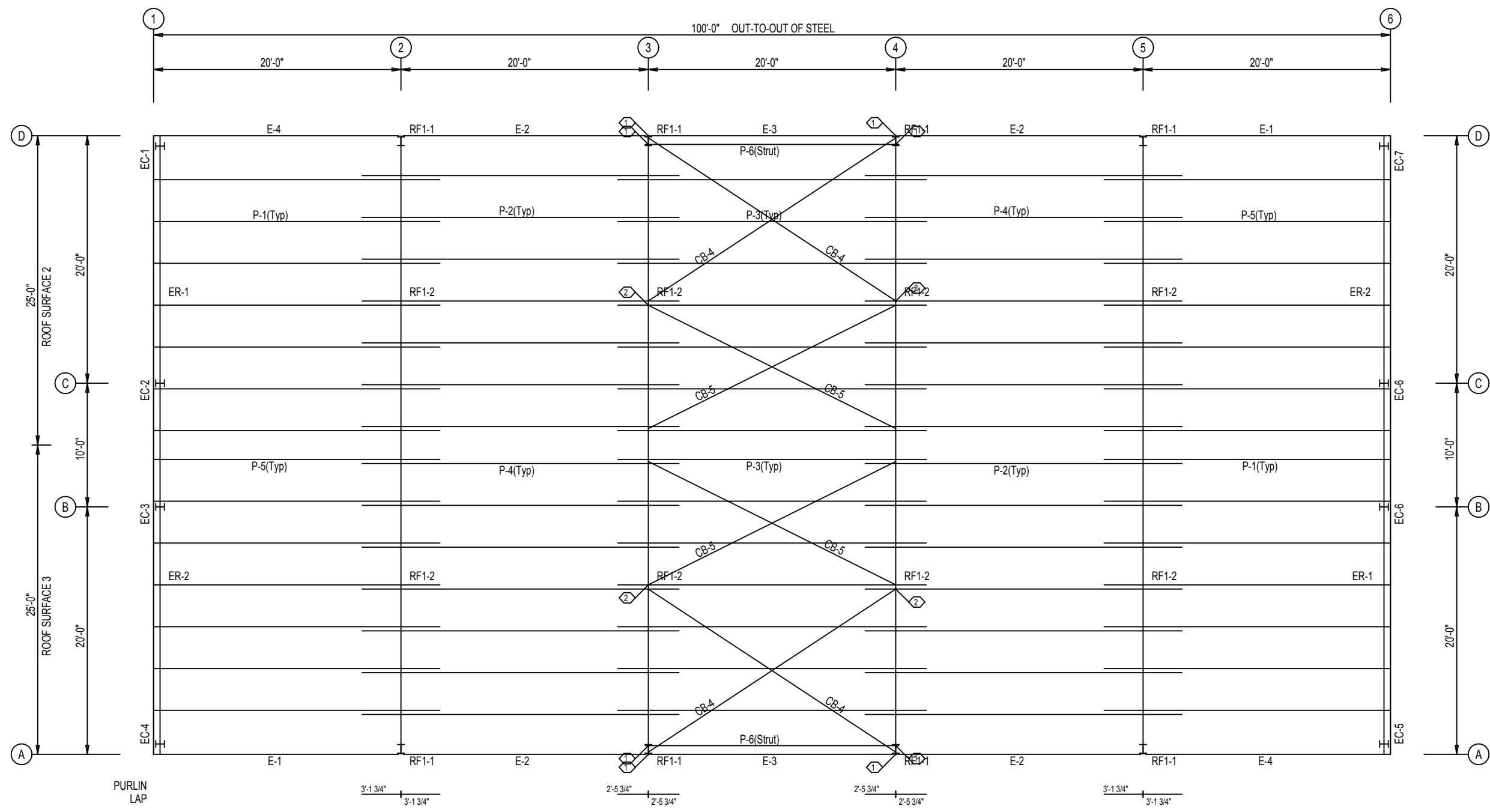

ROOF FRAMING PLAN

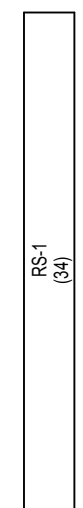
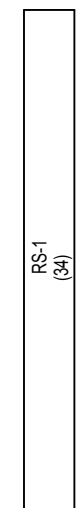

ROOF SHEETING  
 PANELS: 26 Gauge PBR  
 Burnished Slate

**NOT FOR CONSTRUCTION**

SPECIAL BOLTS					
ID	QUAN	TYPE	DIA	LENGTH	WASH
2	2	A325	1/2"	1 1/4"	2

CONNECTION PLATES	
FRAME LINE A	
ID	MARK/PART
1	PC78

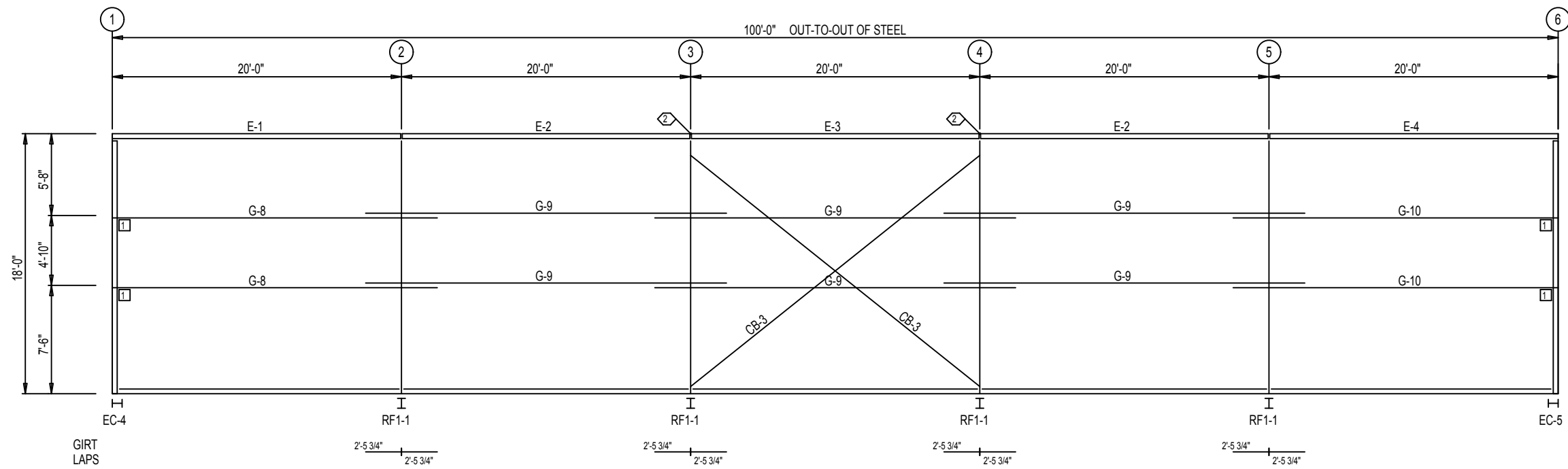

SIDEWALL FRAMING: FRAME LINE A

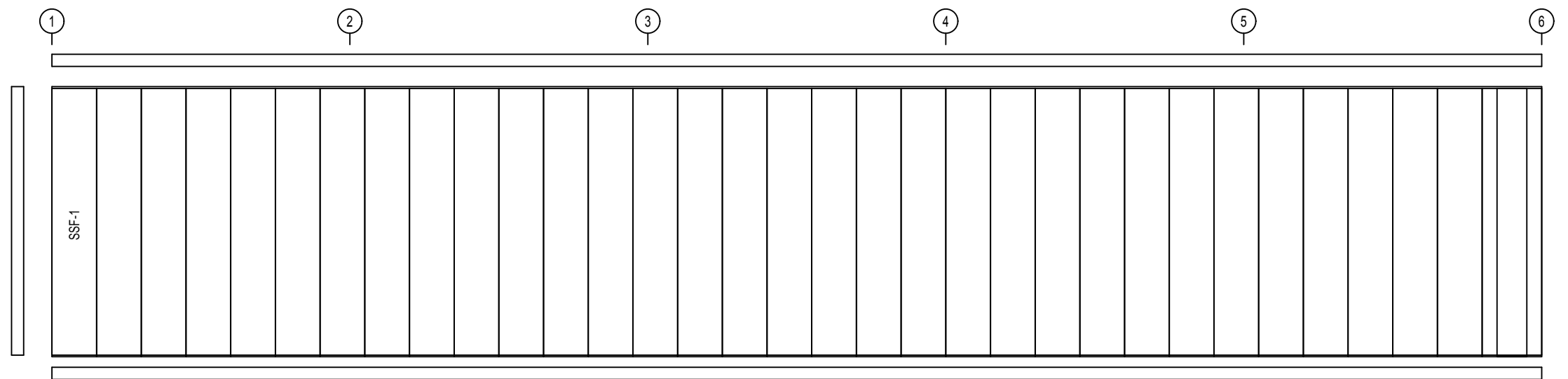

SIDEWALL SHEETING & TRIM: FRAME LINE A

PANELS: 26 Gauge PBR - Polar White

**NOT FOR CONSTRUCTION**

SPECIAL BOLTS					
ID	QUAN	TYPE	DIA	LENGTH	WASH
2	2	A325	1/2"	1 1/4"	2

CONNECTION PLATES	
FRAME LINE D	
ID	MARK/PART
1	PC78

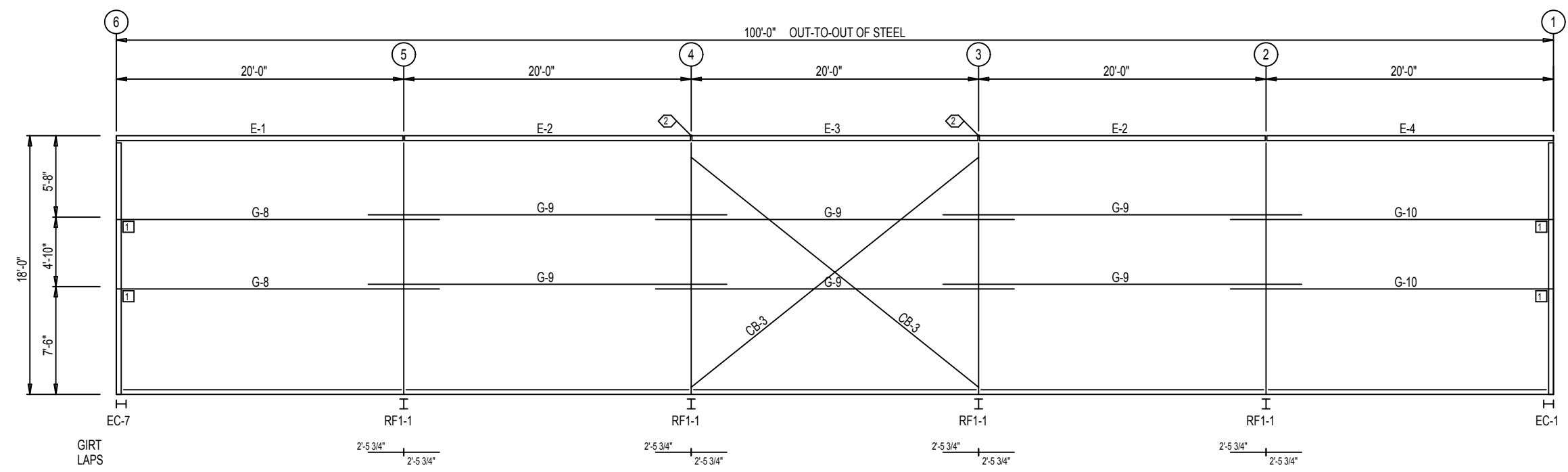

SIDEWALL FRAMING: FRAME LINE D

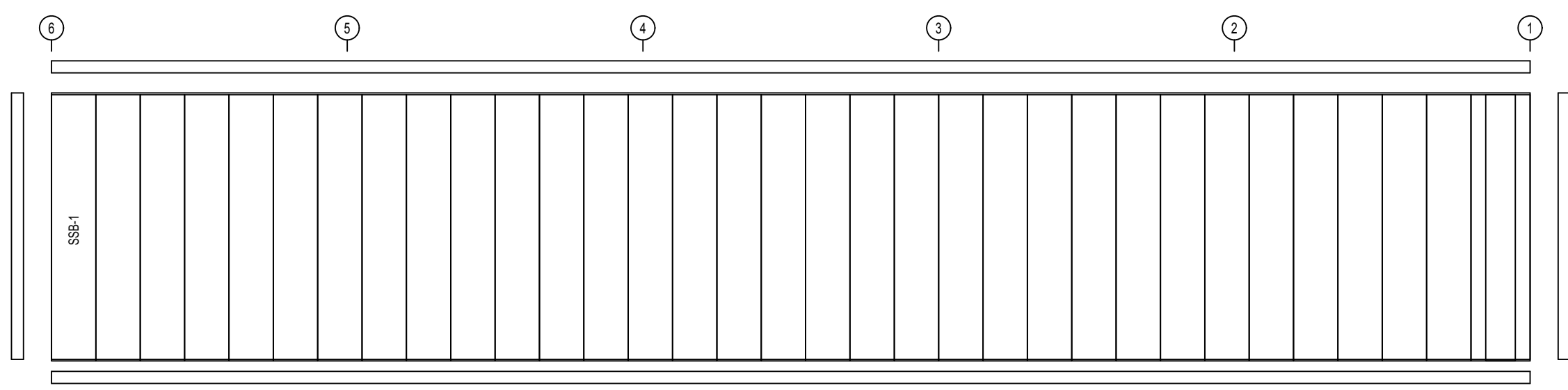

SIDEWALL SHEETING & TRIM: FRAME LINE D  
 PANELS: 26 Gauge PBR - Polar White

**NOT FOR CONSTRUCTION**

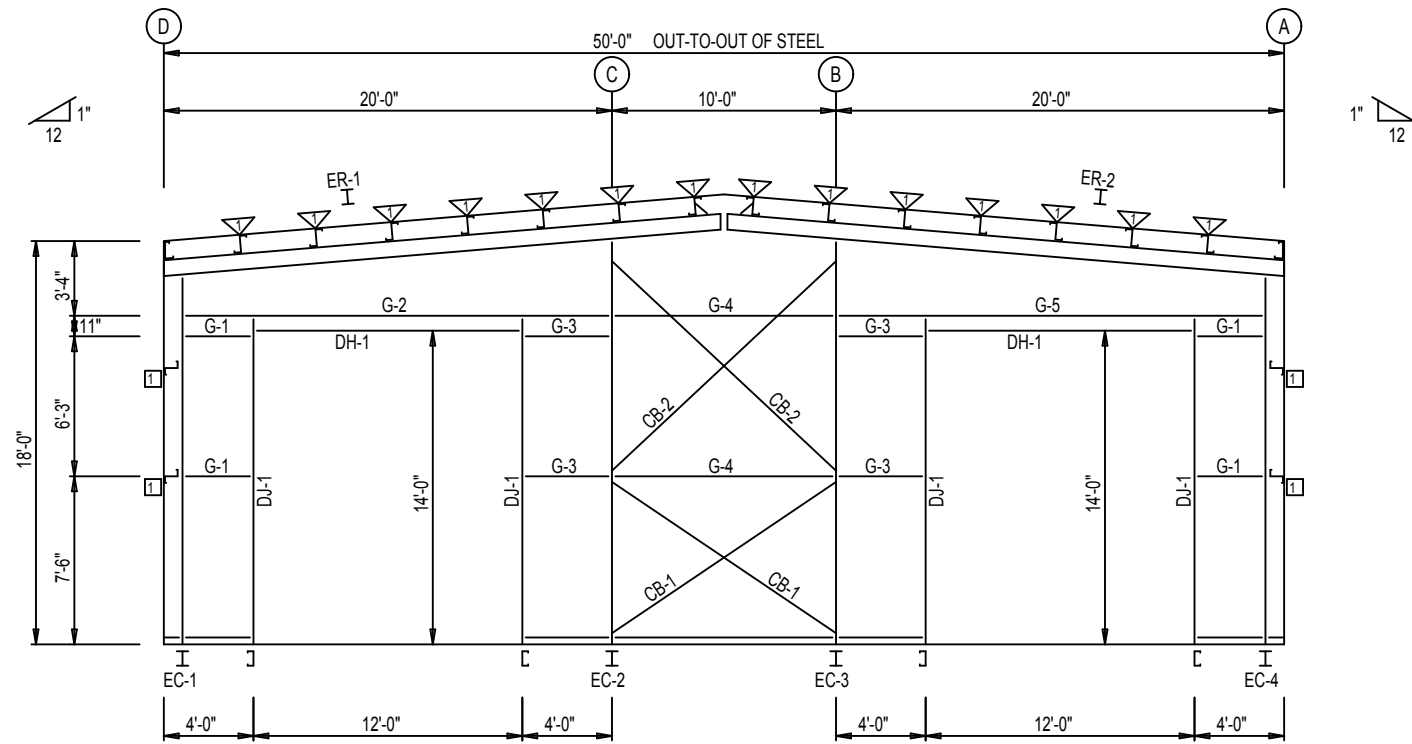

ENDWALL FRAMING: FRAME LINE 1

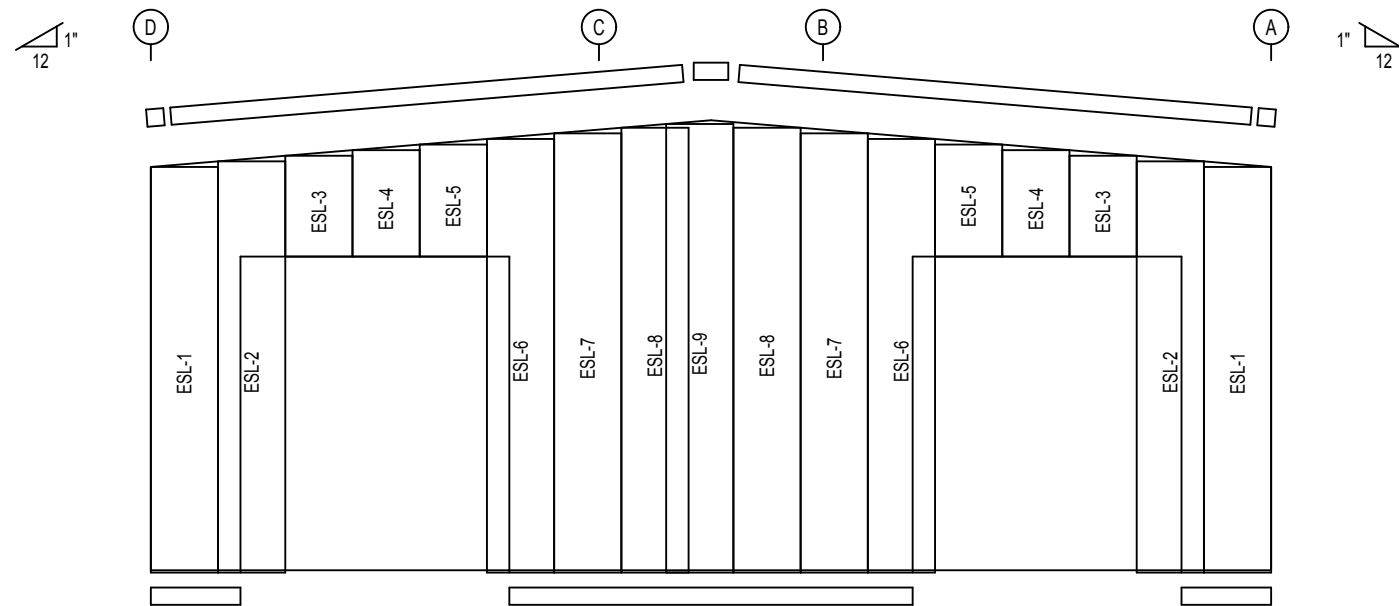

ENDWALL SHEETING & TRIM: FRAME LINE 1

PANELS: 26 Gauge PBR - Polar White

BOLT TABLE				
FRAME LINE 1				
LOCATION	QUAN	TYPE	DIA	LENGTH
ER-1/ER-2	8	A325	5/8"	1 3/4"
Columns/Raf	4	A325	1/2"	1 1/4"

FLANGE BRACE TABLE		
FRAME LINE 1		
▽ ID	PART	LENGTH
FB31	L2X2X14G	2'-7"

CONNECTION PLATES	
FRAME LINE 1	
□ ID	MARK/PART
1	PC78

**NOT FOR CONSTRUCTION**

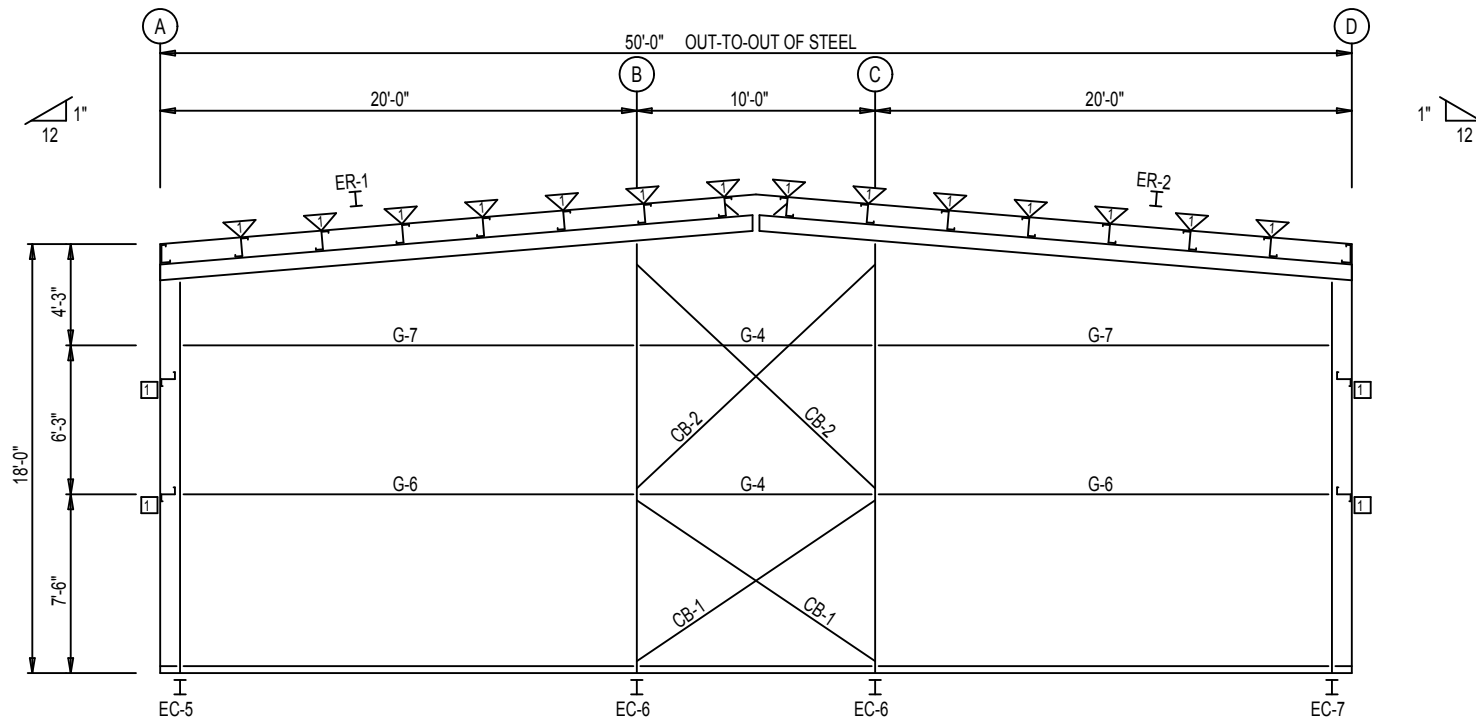

ENDWALL FRAMING: FRAME LINE 6

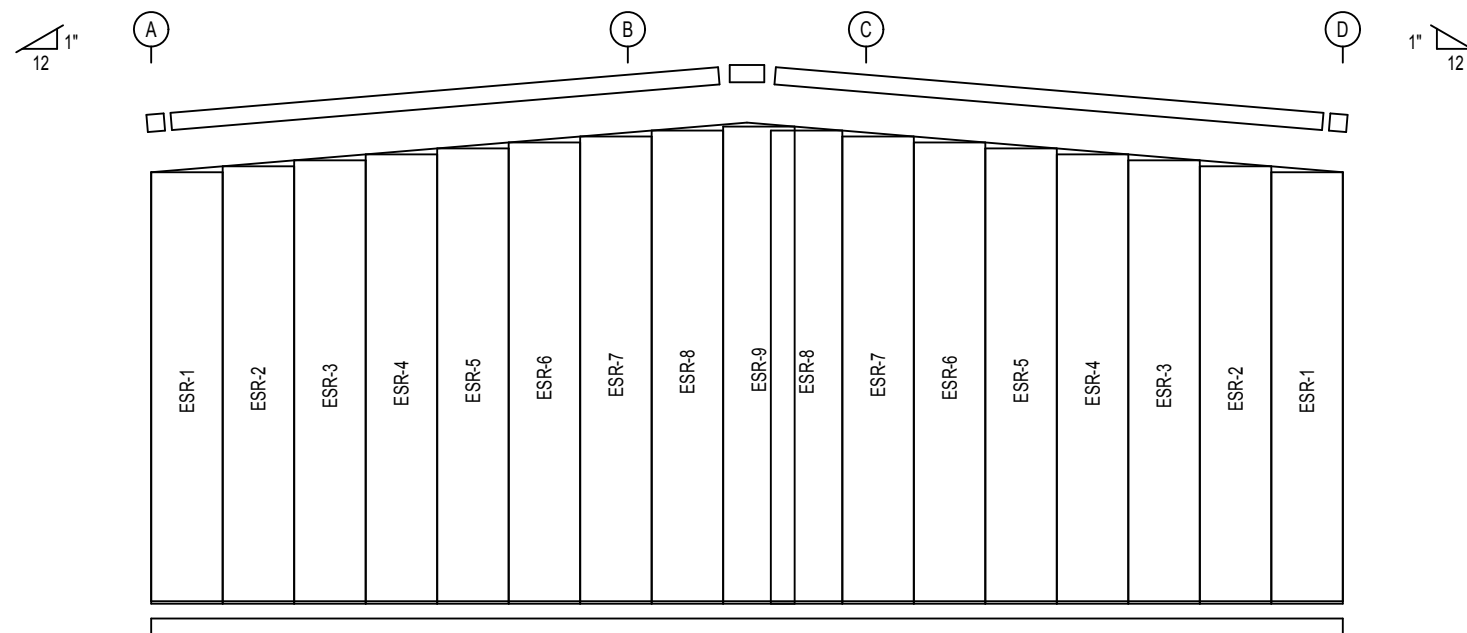

ENDWALL SHEETING & TRIM: FRAME LINE 6

PANELS: 26 Gauge PBR - Polar White

BOLT TABLE				
FRAME LINE 6				
LOCATION	QUAN	TYPE	DIA	LENGTH
ER-1/ER-2	8	A325	5/8"	1 3/4"
Columns/Raf	4	A325	1/2"	1 1/4"

FLANGE BRACE TABLE		
FRAME LINE 6		
▽ ID	PART	LENGTH
FB31	L2X2X14G	2'-7"

CONNECTION PLATES	
FRAME LINE 6	
□ ID	MARK/PART
1	PC78

**NOT FOR CONSTRUCTION**



