

NOT FOR CONSTRUCTION

○ Dia= 5/8"

⊗ Dia= 3/4"

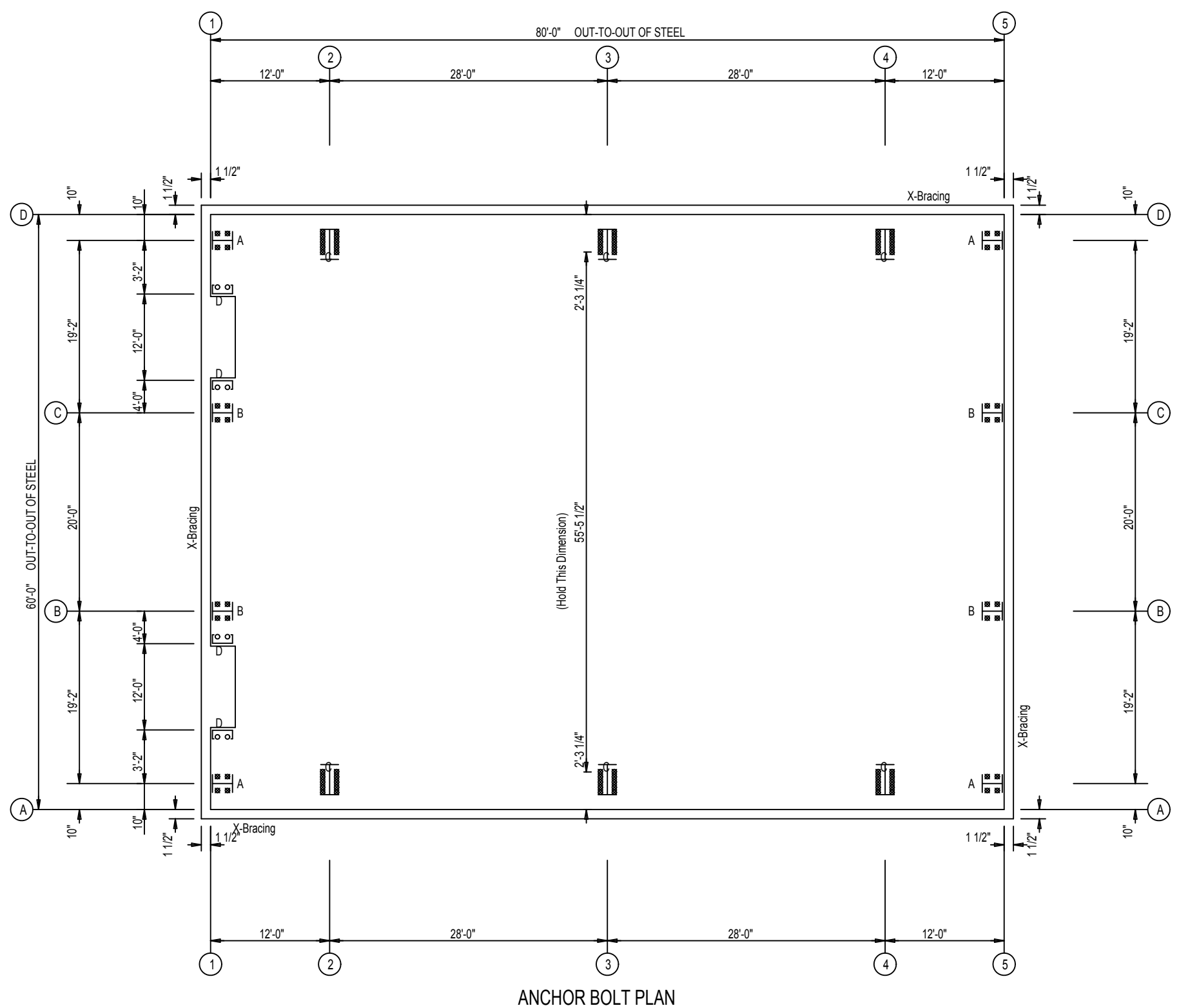

ANCHOR BOLT PLAN

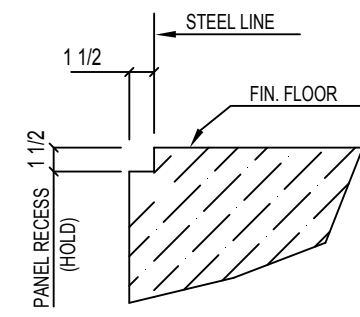

CONCRETE NOTCH DETAIL

NOT FOR CONSTRUCTION

SPECIAL BOLTS					
ROOF PLAN					
ID	QUAN	TYPE	DIA	LENGTH	WASH
1	4	A325	1/2"	1 1/4"	0
2	2	A325	1/2"	1 1/4"	2

CONNECTION PLATES	
ROOF PLAN	
ID	MARK/PART
1	SC18

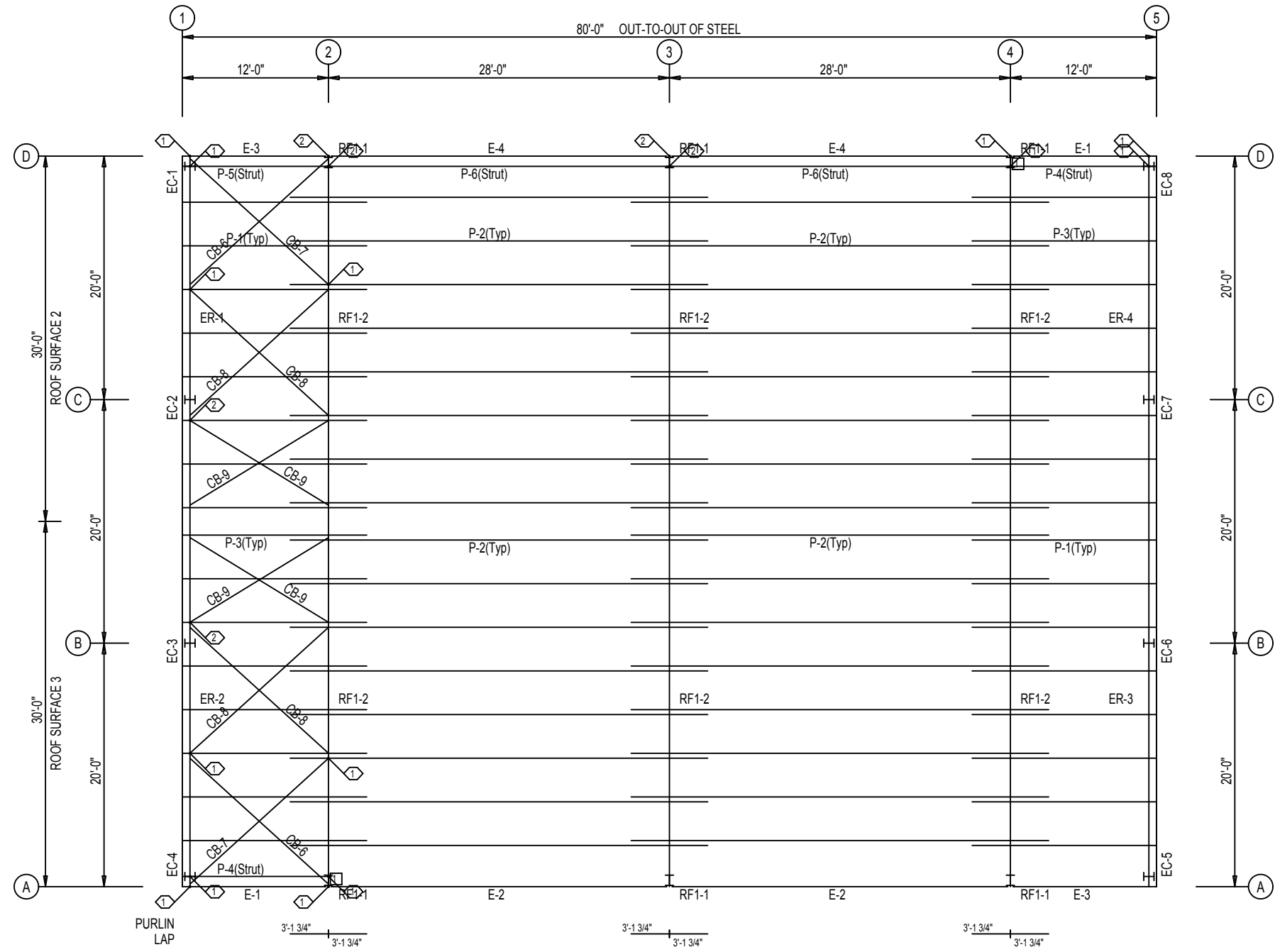

ROOF FRAMING PLAN

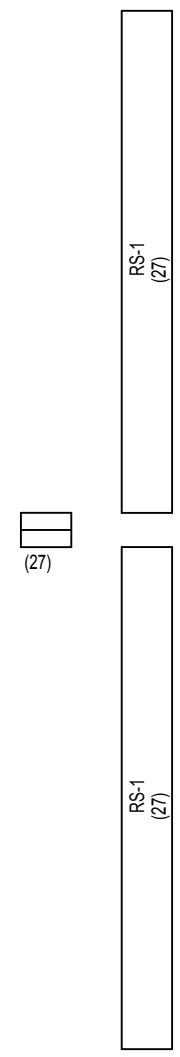

ROOF SHEETING
 PANELS: 26 Gauge PBR
 Burnished Slate

NOT FOR CONSTRUCTION

SPECIAL BOLTS					
ROOF PLAN					
ID	QUAN	TYPE	DIA	LENGTH	WASH
1	4	A325	1/2"	1 1/4"	0
2	2	A325	1/2"	1 1/4"	2

CONNECTION PLATES	
ROOF PLAN	
ID	MARK/PART
1	SC18

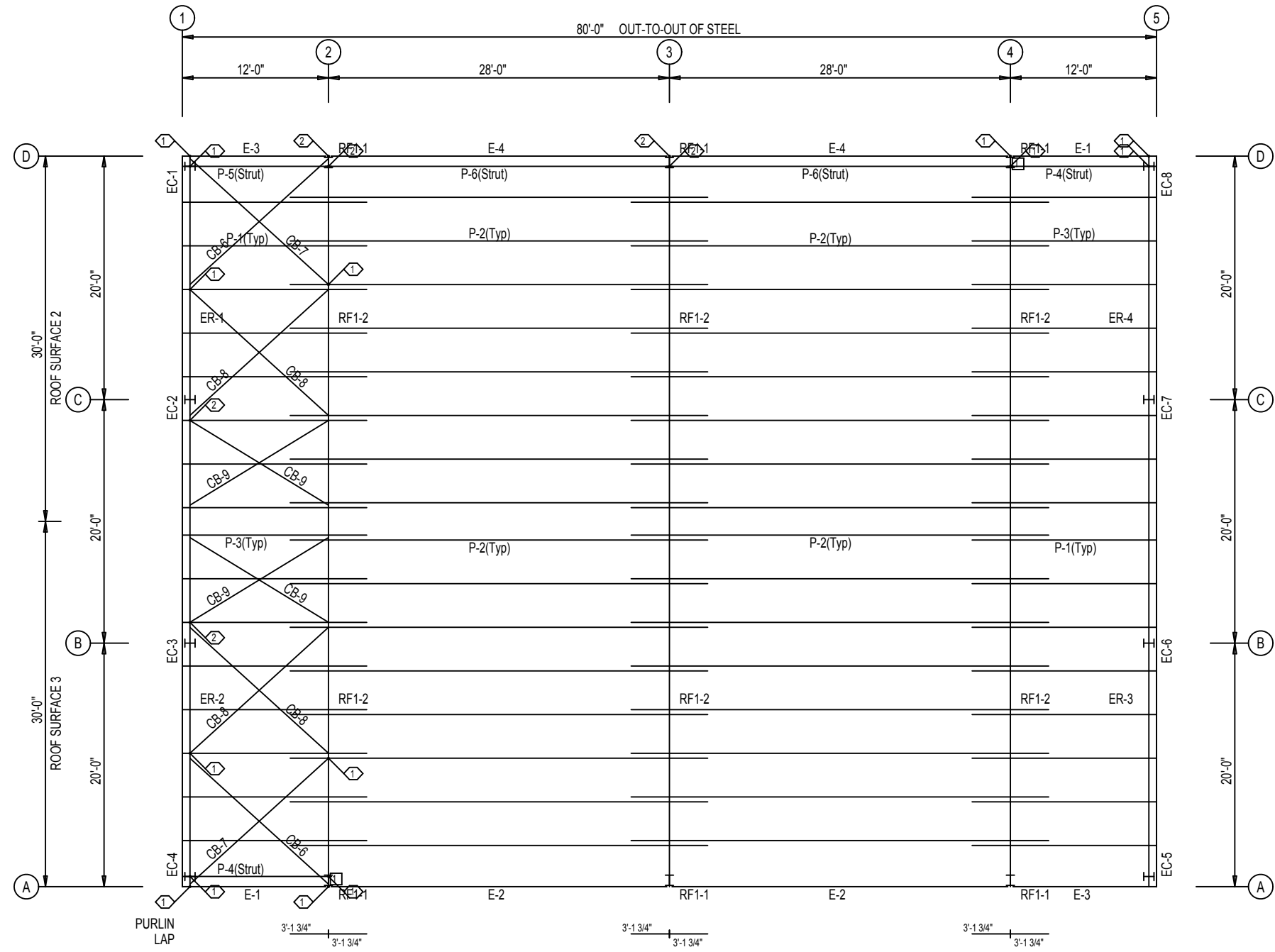

ROOF FRAMING PLAN

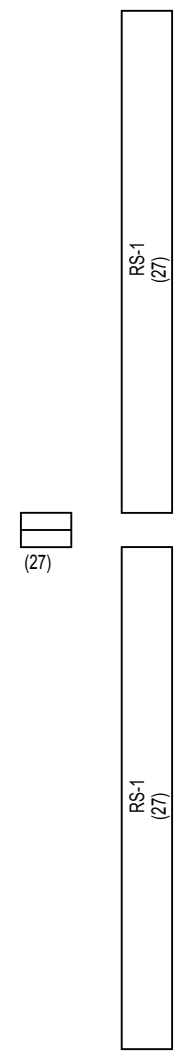

ROOF SHEETING
 PANELS: 26 Gauge PBR
 Burnished Slate

NOT FOR CONSTRUCTION

SPECIAL BOLTS					
ID	QUAN	TYPE	DIA	LENGTH	WASH
1	4	A325	1/2"	1 1/4"	0

CONNECTION PLATES FRAME LINE A	
ID	MARK/PART
1	SC18
2	PC78

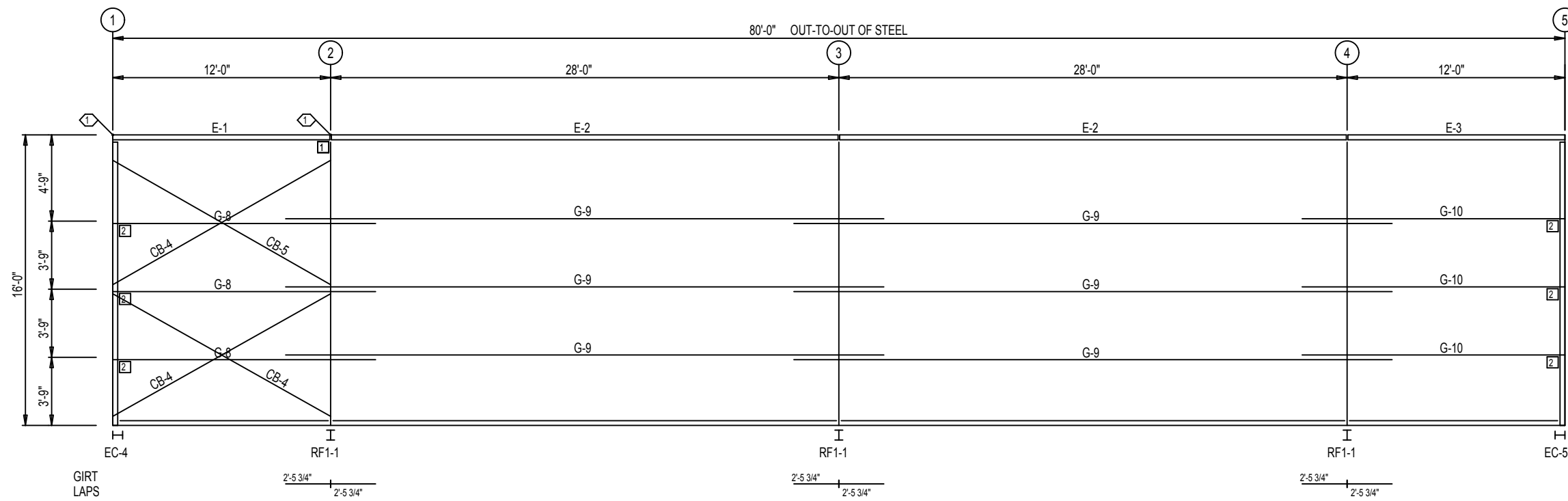

SIDEWALL FRAMING: FRAME LINE A

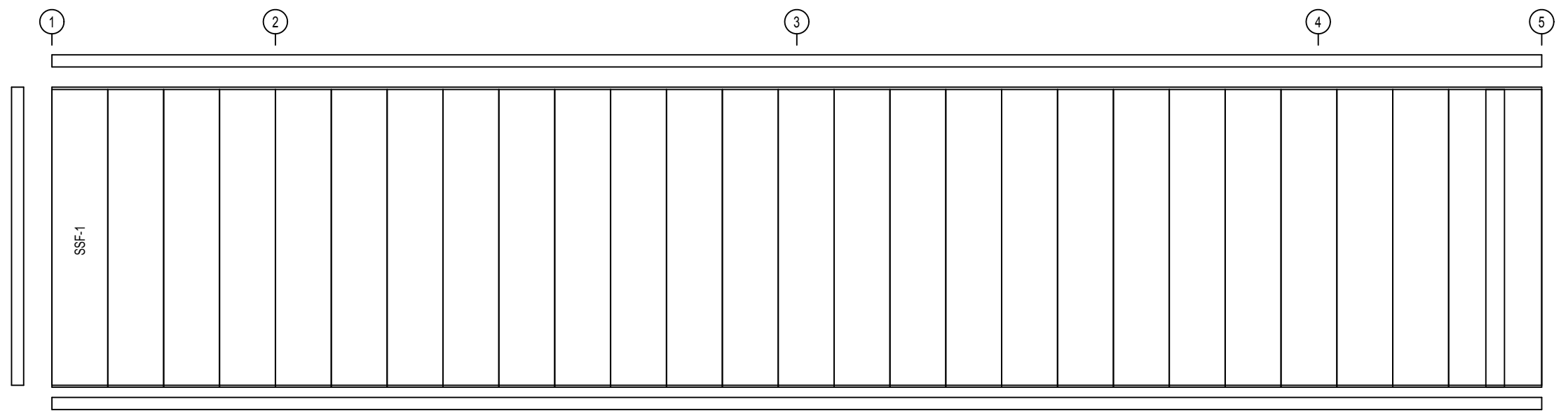

SIDEWALL SHEETING & TRIM: FRAME LINE A

PANELS: 26 Gauge PBR - Burnished Slate

NOT FOR CONSTRUCTION

SPECIAL BOLTS					
ID	QUAN	TYPE	DIA	LENGTH	WASH
1	4	A325	1/2"	1 1/4"	0
3	2	A325	1/2"	1 1/4"	2

CONNECTION PLATES FRAME LINE D	
ID	MARK/PART
1	SC18
2	PC78

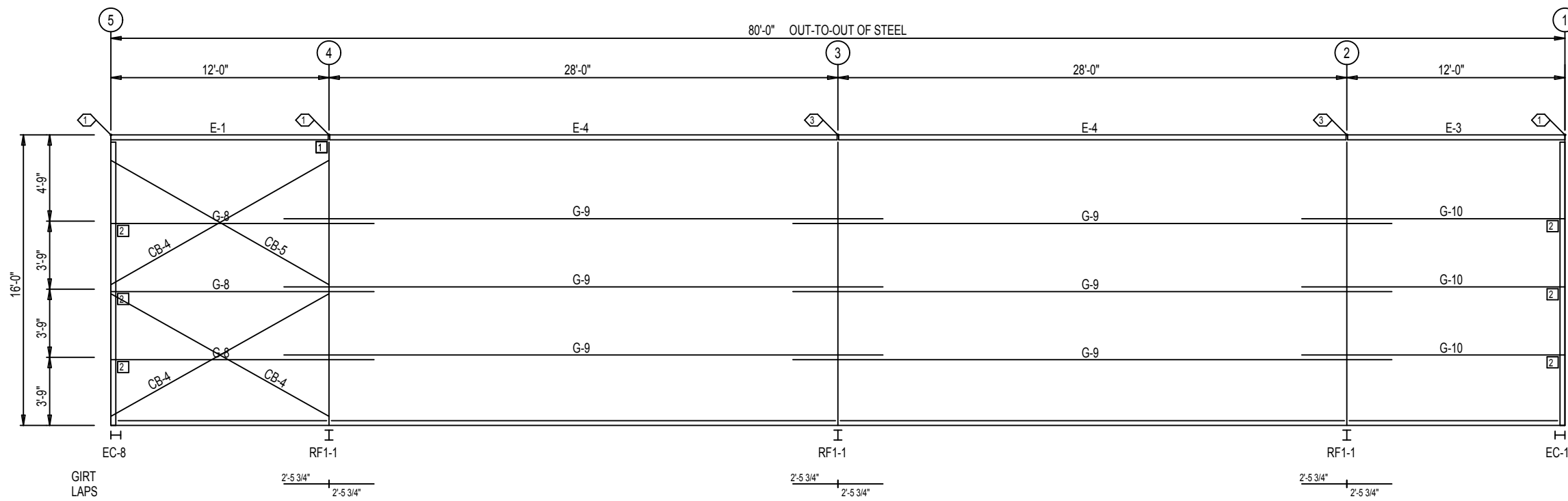

SIDEWALL FRAMING: FRAME LINE D

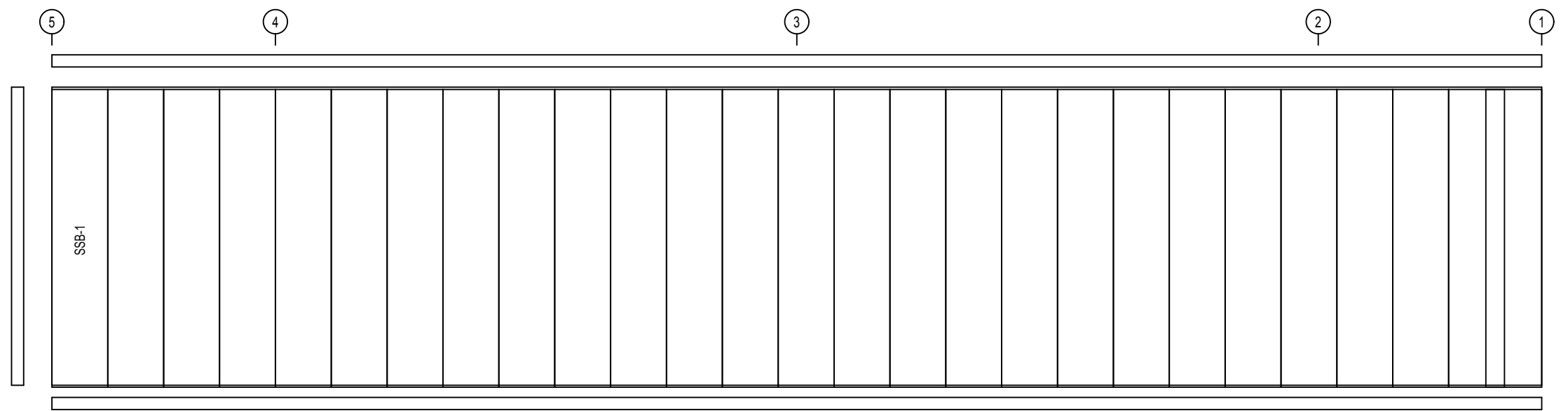

SIDEWALL SHEETING & TRIM: FRAME LINE D

PANELS: 26 Gauge PBR - Burnished Slate

NOT FOR CONSTRUCTION

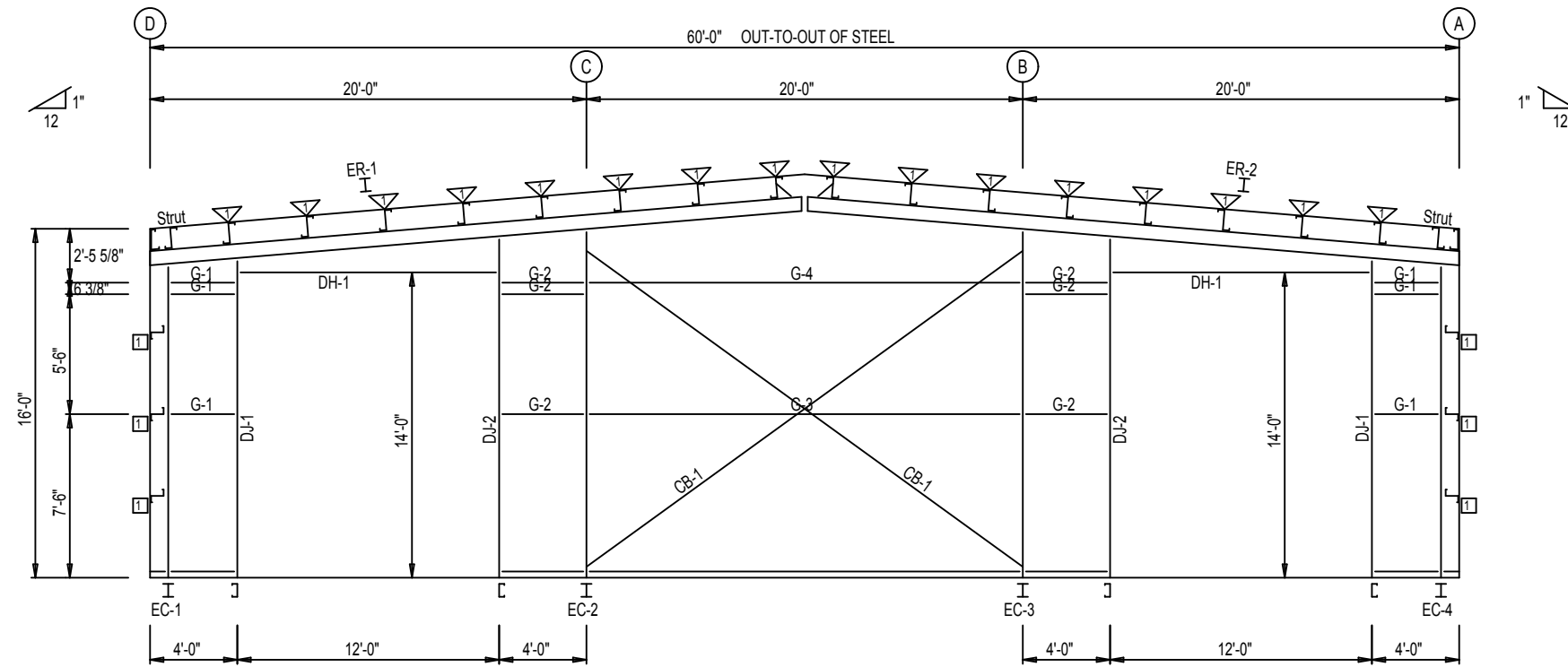

ENDWALL FRAMING: FRAME LINE 1

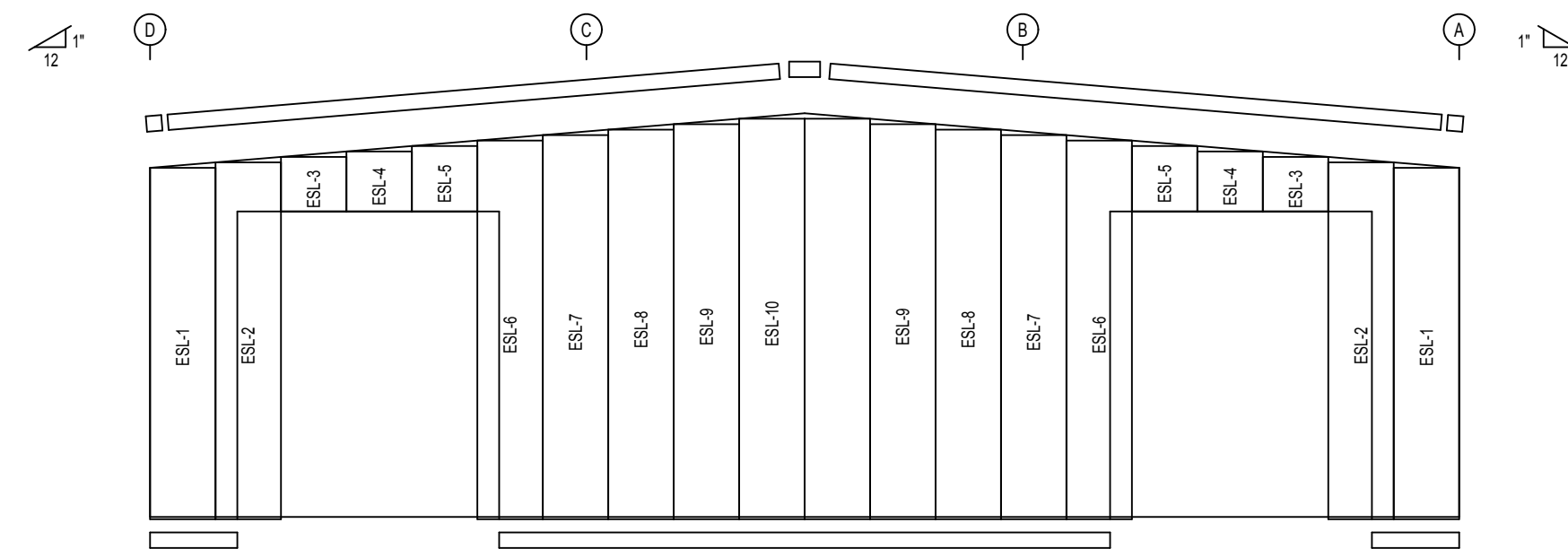

ENDWALL SHEETING & TRIM: FRAME LINE 1

PANELS: 26 Gauge PBR - Burnished Slate

BOLT TABLE FRAME LINE 1				
LOCATION	QUAN	TYPE	DIA	LENGTH
ER-1/ER-2	8	A325	5/8"	1 3/4"
Columns/Raf	4	A325	1/2"	1 1/4"
Jamb	2	A325	1/2"	1 1/4"

FLANGE BRACE TABLE FRAME LINE 1		
▽ ID	PART	LENGTH
FB30.5	L2X2X14G	2'-6 1/2"

CONNECTION PLATES FRAME LINE 1	
□ ID	MARK/PART
1	PC78

NOT FOR CONSTRUCTION

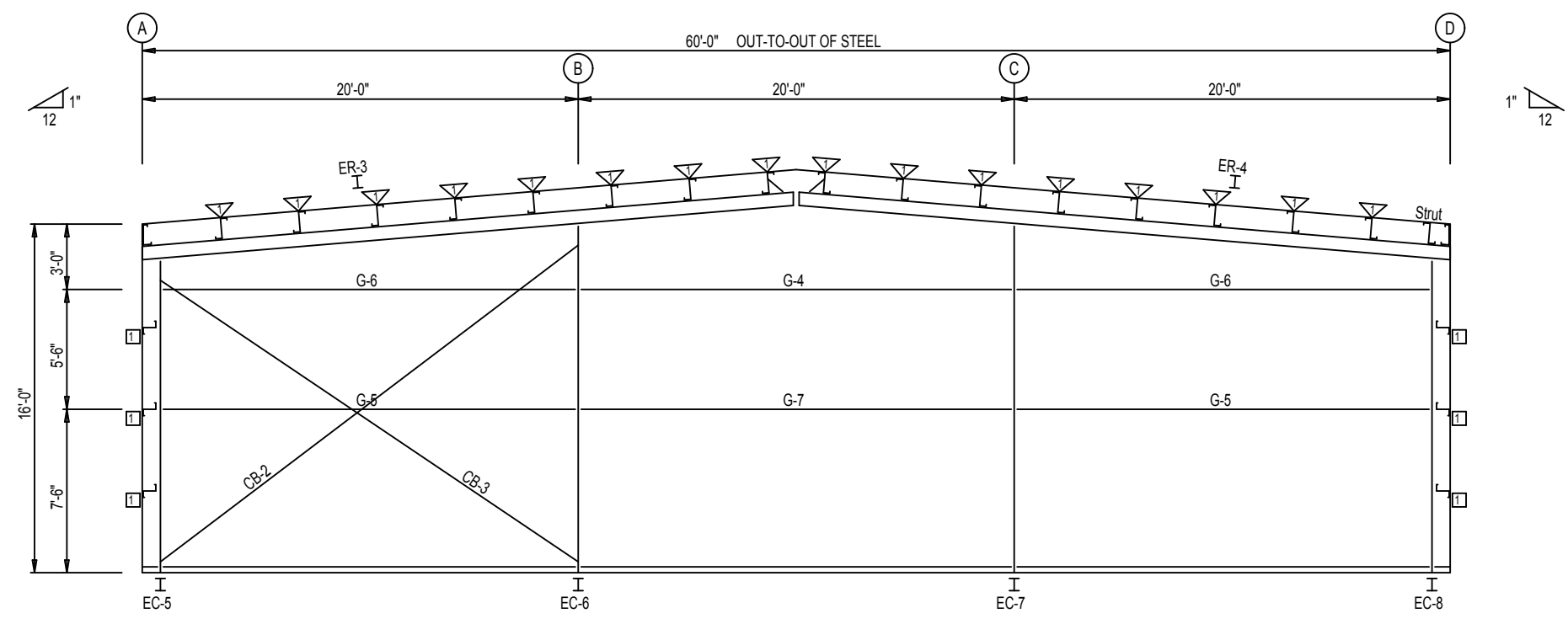

ENDWALL FRAMING: FRAME LINE 5

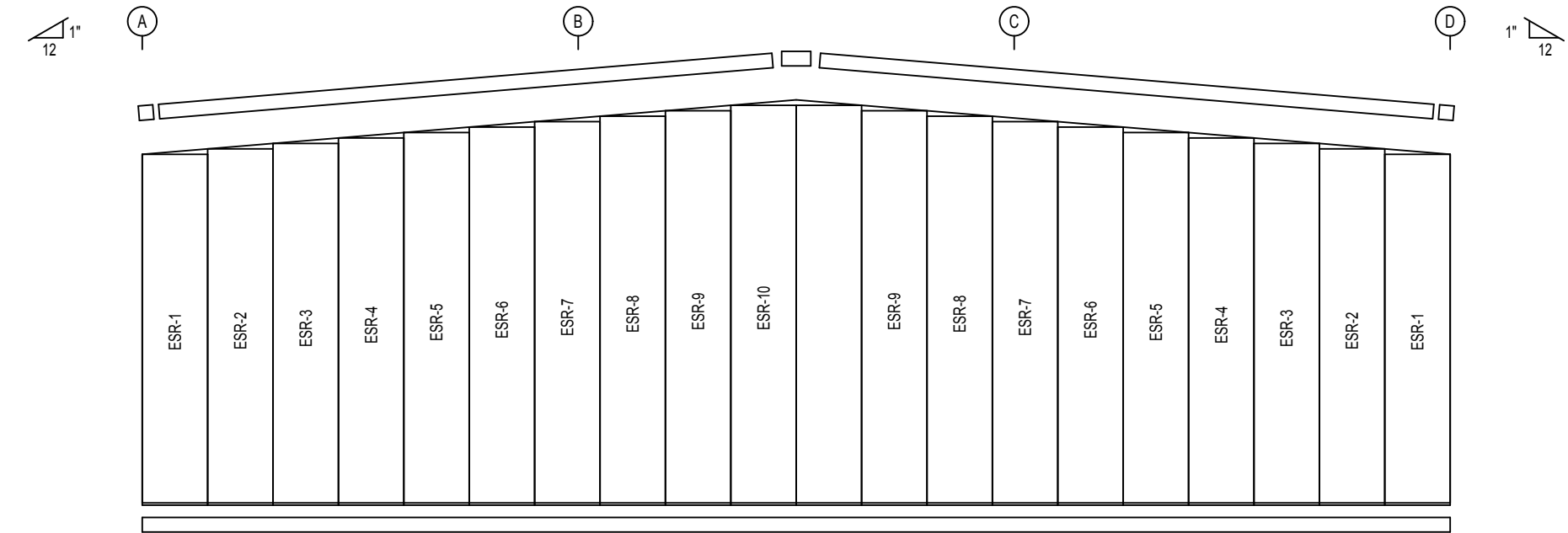

ENDWALL SHEETING & TRIM: FRAME LINE 5
 PANELS: 26 Gauge PBR - Burnished Slate

BOLT TABLE				
FRAME LINE 5				
LOCATION	QUAN	TYPE	DIA	LENGTH
ER-3/ER-4	8	A325	5/8"	1 3/4"
Columns/Raf	4	A325	1/2"	1 1/4"

FLANGE BRACE TABLE		
FRAME LINE 5		
▽ ID	PART	LENGTH
FB30.5	L2X2X14G	2'-6 1/2"

CONNECTION PLATES	
FRAME LINE 5	
□ ID	MARK/PART
1	PC78

NOT FOR CONSTRUCTION

STIFFENER TABLE				
Mark	Stiff Mark	Width	Plate Size Thick	Length
RF1-1	ST1	6"	3/8"	42"

▽ FLANGE BRACES: FBxx (1 or 2)
 xx=length(in)
 (1) One Side; (2) Two Sides
 C - L2X2X1/8
 D - L25X25X3
 A - L2X2X1/4G

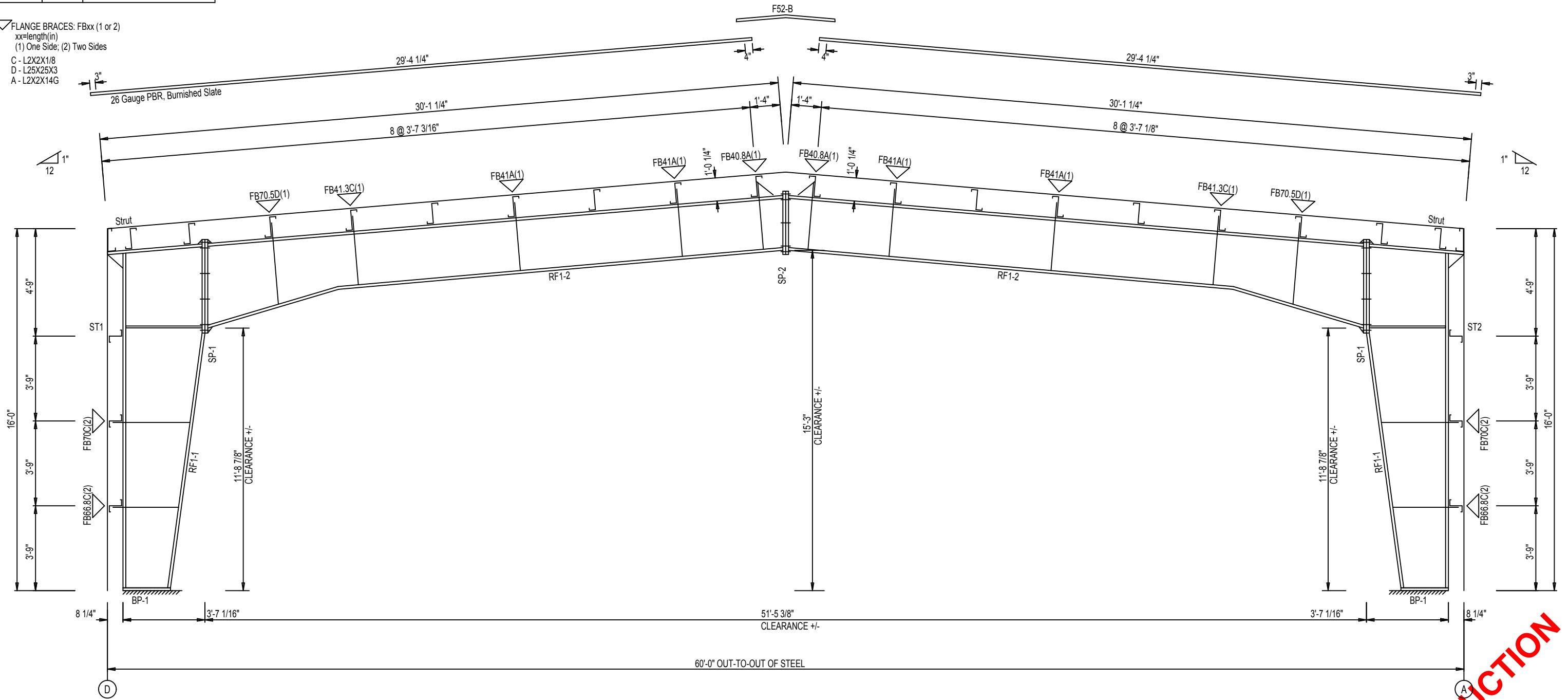

RIGID FRAME ELEVATION: FRAME LINE 2 3 4

NOT FOR CONSTRUCTION